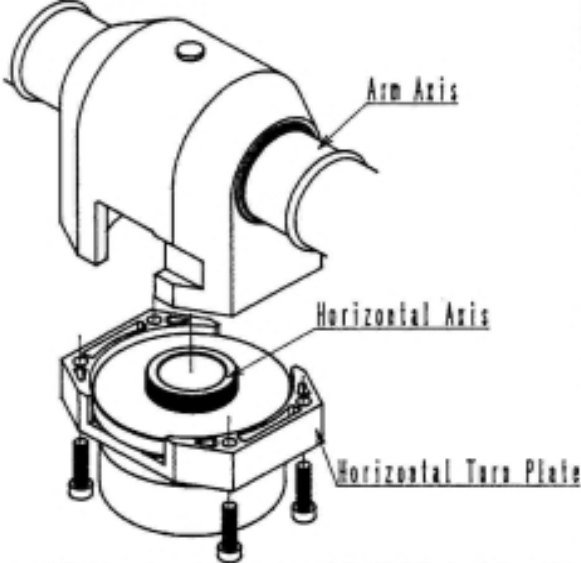
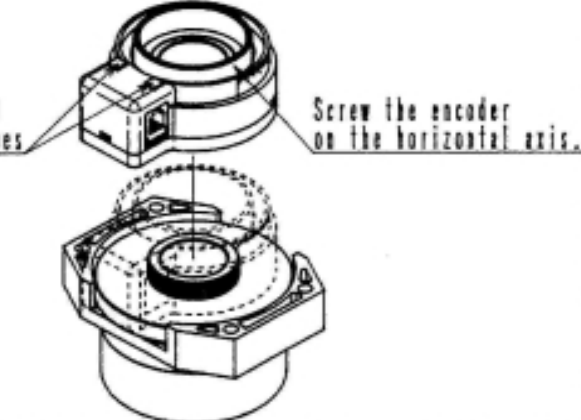
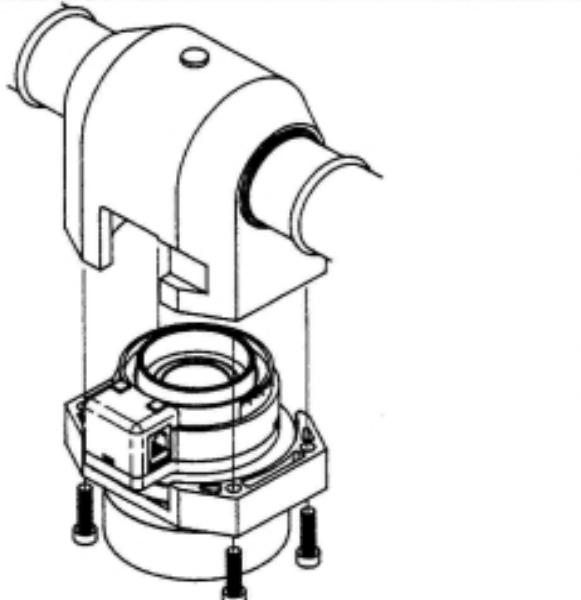

HOW TO INSTALL ENCODERS ON FORK MOUNT

1. Installing the Encoder on the Horizontal Movement Axis

<p>(1)</p>  <p>Arm Axis</p> <p>Horizontal Axis</p> <p>Horizontal Turn Plate</p>	<ul style="list-style-type: none">○ Unscrew the arm axis from the horizontal turn plate.
<p>(2)</p>  <p>Double-sided Adhesive Tapes</p> <p>Screw the encoder on the horizontal axis.</p>	<ul style="list-style-type: none">○ If the encoder is not screwed tightly on the horizontal axis, there may be a display error on STELLAR GUIDE.○ The double-sided adhesive tapes are to fix the encoder to the arm axis bracket.
<p>(3)</p> 	<ul style="list-style-type: none">○ Screw the arm axis on the horizontal turn Plate.

2. Installing the Encoder on the Arm

(1)

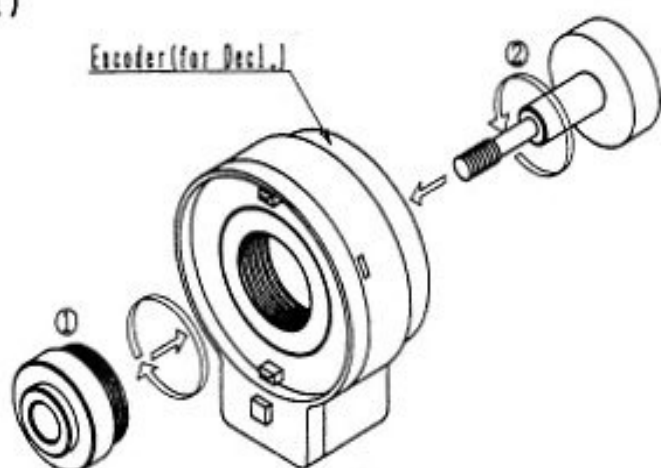

- To install the encoder on the arm, optional parts ① and ② are needed.
- Screw the part ① on the encoder securely. If it is not screwed securely, there may be a display error on STELLAR GUIDE.

(2)

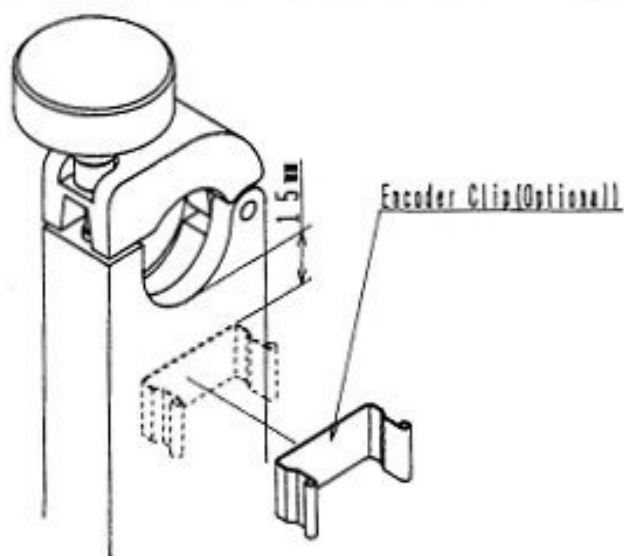

- Attach the encoder clip to the left or right arm with the double-sided adhesive tape.

(3)

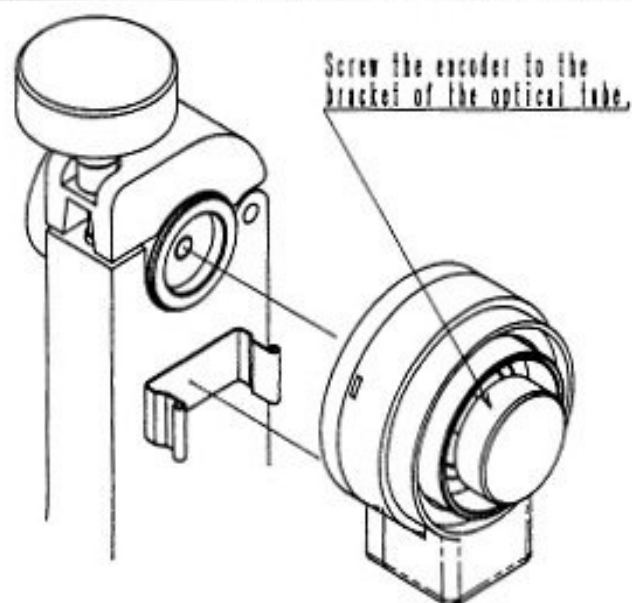

- Install the encoder on the arm.
- If the encoder clipping is loose, bend the encoder clip inside slightly.

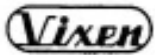

OPTIONAL ACCESSORIES FOR FORK MOUNT

The following optional accessories are available.

- ① Fork-Mount Swing Bracket
- ② Encoders
- ③ Encoder Attachments for Fork Mount
- ④ Encoder Display Unit – STELLAR GUIDE

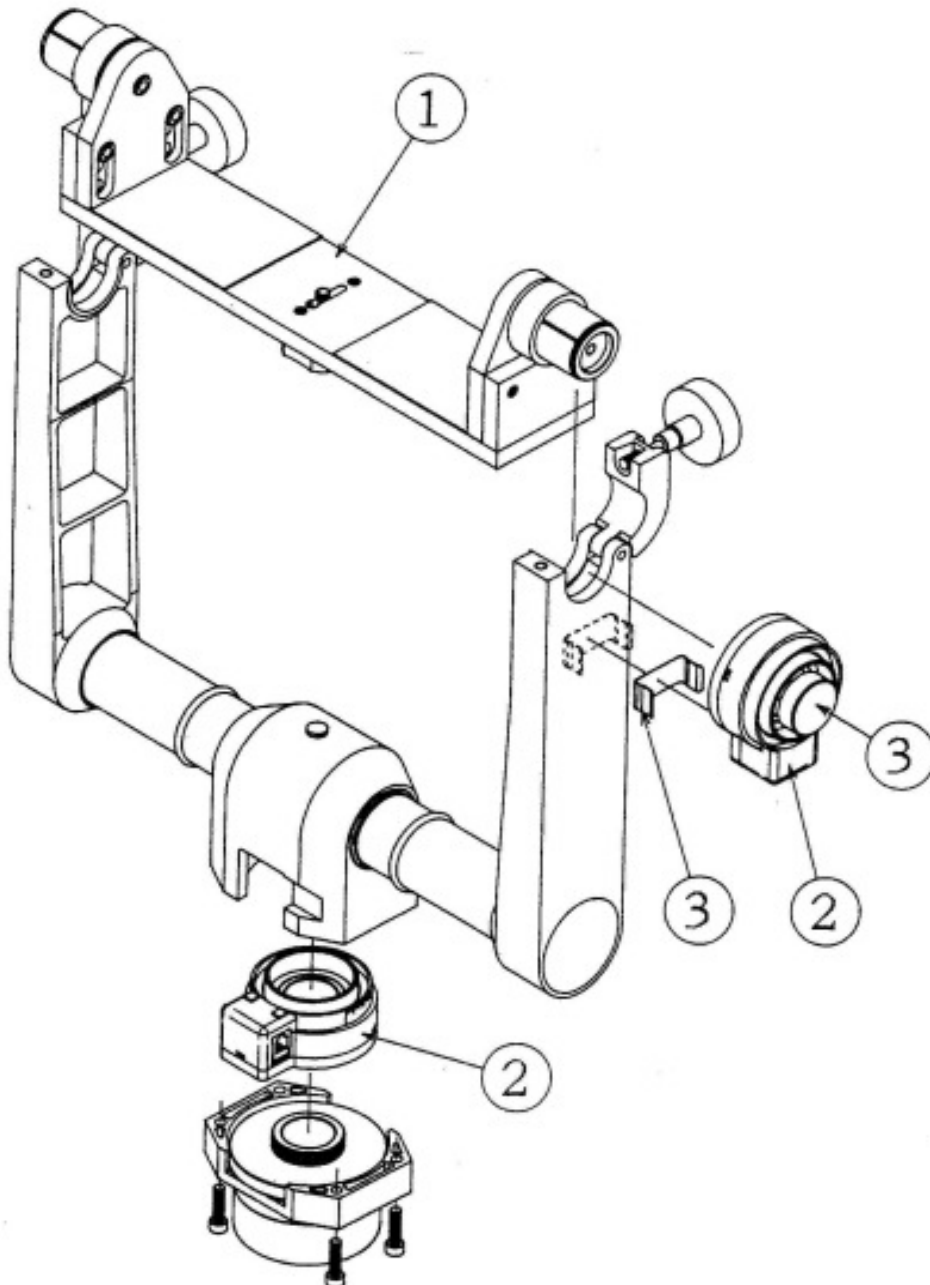

Vixen GP Encoder Cable Wiring to Digital Setting Circles

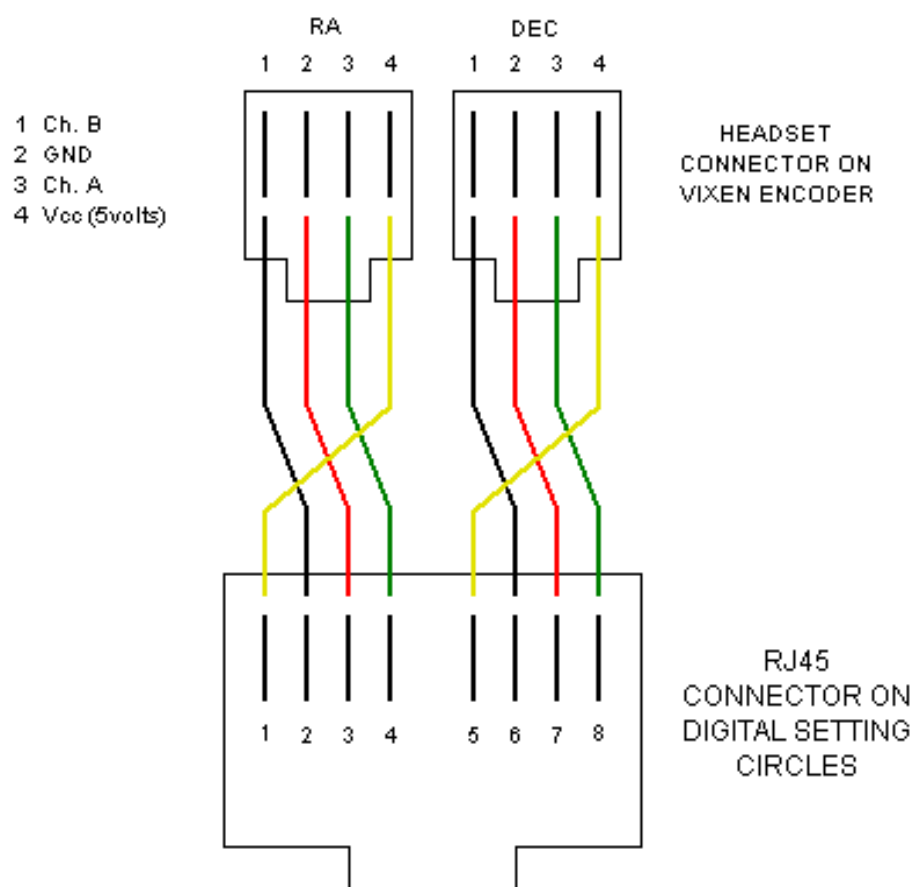

Drawing shows female connectors

12/01/1999

HOW TO INSTALL THE ENCODERS

1. Installing the R.A. Encoder

- ① Remove the polar axis scope.
(As it is screwed tightly, turn it strongly and carefully.)
- ② Remove the R.A. and hour graduation ring.

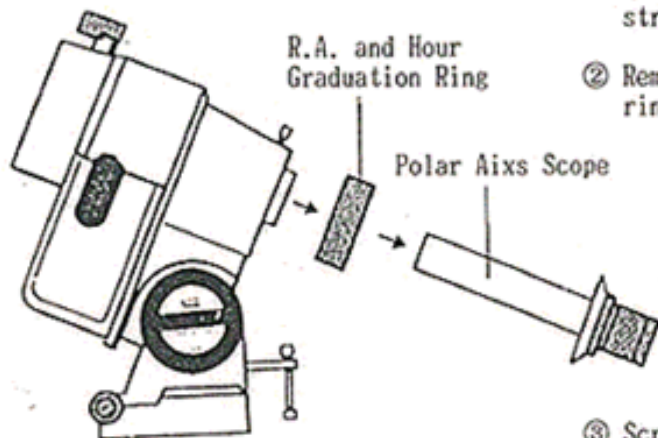

- ③ Screw the R.A. encoder on the mount so that the small square protrusion on the encoder sets into the notch on the mount.

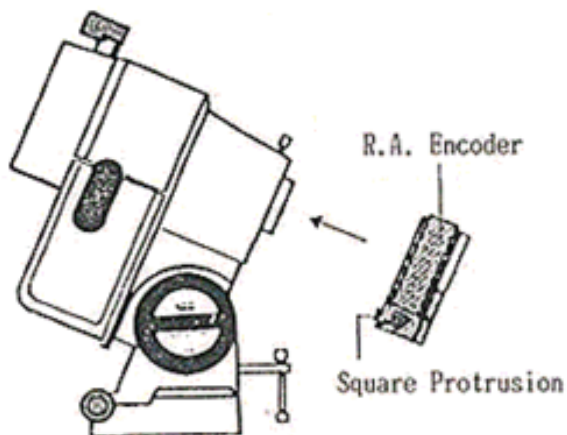

- ④ Re-install the polar axis scope and align it. (For aligning the polar axis scope, refer to the instruction manual for "GREAT POLARIS" and "GP-DX" telescopes.)

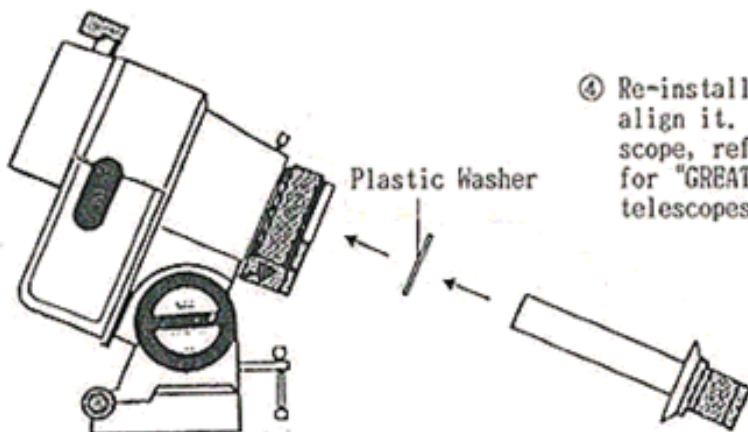

2. Installing the Decl. Encoder

- ① Remove the weight shaft, weight-shaft lock ring and Decl. graduation ring.

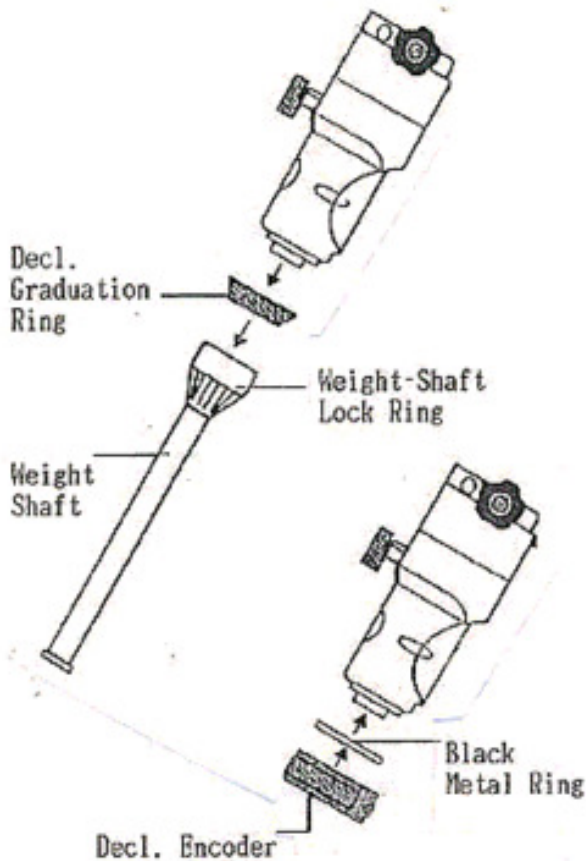

- ② Place the Decl. encoder on the mount after placing the black metal ring between them. Tighten the encoder to the mount by turning the black screwing ring inside the encoder. For the encoder to fit tight, the two small protrusions on the encoder must set the notches on the mount.

- ③ Screw the spacing ring on the weight-shaft lock ring.

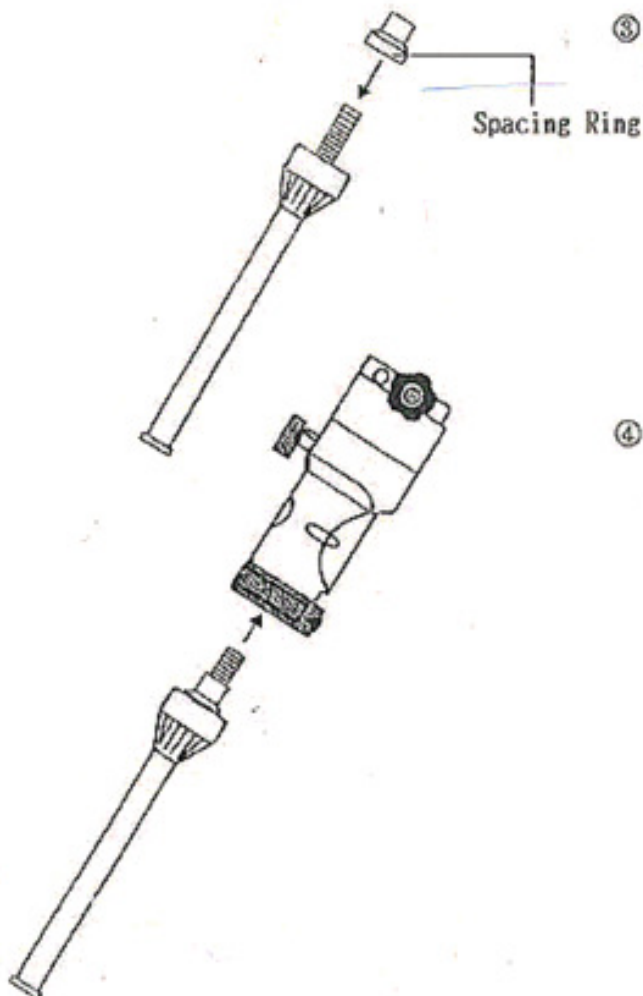

- ④ Attach the weight shaft to the mount and secure it by turning the weight-shaft lock ring.