

**"GREAT POLARIS"
"GP-DX"
EQUATORIAL MOUNT TELESCOPE**

INSTRUCTION MANUAL



CONTENTS

"GREAT POLARIS" AND "GP-DX" EQUATORIAL MOUNTS.....	3
FOR FIRST TIME TELESCOPE USERS	4
Step 1 Proper assembly of the telescope	4
Step 2 Installation of an eyepiece	4
Step 3 First operation of the telescope	4
Step 4 Your first look.....	5
Step 5 Changing eyepieces	7
Step 6 Use of the finderscope	7
Step 7 Your first observation—the Moon!.....	8
Step 8 Observing Jupiter and Saturn	9
Step 9 Observing the Sun.....	9
Step 10 General Cautions	10
HOW TO SET UP THE EQUATORIAL MOUNT TELESCOPE.....	11
Roughly Aligning the Polar Axis of the Telescope	11
Using your Polar Axis Scope in the Northern Hemisphere	12
Using your Polar Axis Scope in the Southern Hemisphere	13
Aligning the Polar Axis Scope.....	13
HOW TO USE THE R.A. AND DECL. GRADUATION RINGS (SETTING CIRCLES).....	15
HOW TO COLLIMATE THE OPTICAL SYSTEM OF A NEWTONIAN REFLECTOR	16
CAMERA ADAPTERS	17
MOTOR DRIVES	18

PRECAUTIONS

Do not touch the lens or mirror with a finger.



Never wipe the lens or mirror with a hard cloth. Use a soft silicone cloth or lens cleaning tissue.



Do not drop or subject the telescope to hard knocks.

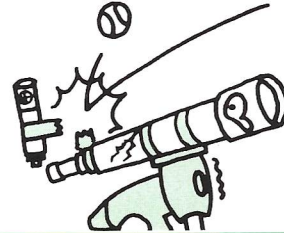

Never use the telescope in the water or in the rain.

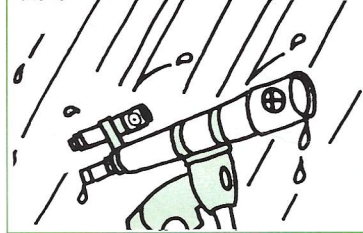

Do not leave the telescope in a dusty place.

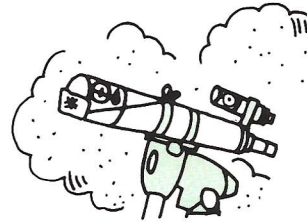

Avoid setting up the telescope at a rough place.

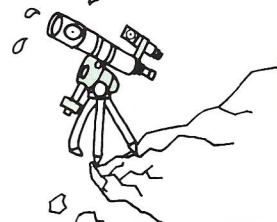

When storing or transporting the telescope, release the R. A. and Decl. clamps. Also remove the fine adjustment knob and handle from the mount.



NEVER LOOK DIRECTLY AT THE SUN WITH THE TELESCOPE, FINDERSCOPE OR EYEPIECE. EYE DAMAGE AND/OR DAMAGE TO THE INSTRUMENTS MAY RESULT.

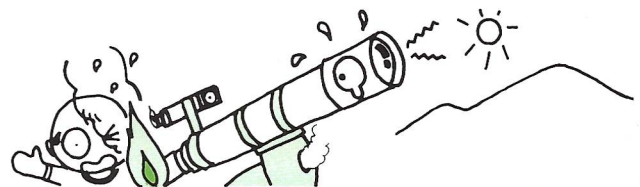

"GREAT POLARIS" AND "GP-DX" EQUATORIAL MOUNTS

"GREAT POLARIS" Mount

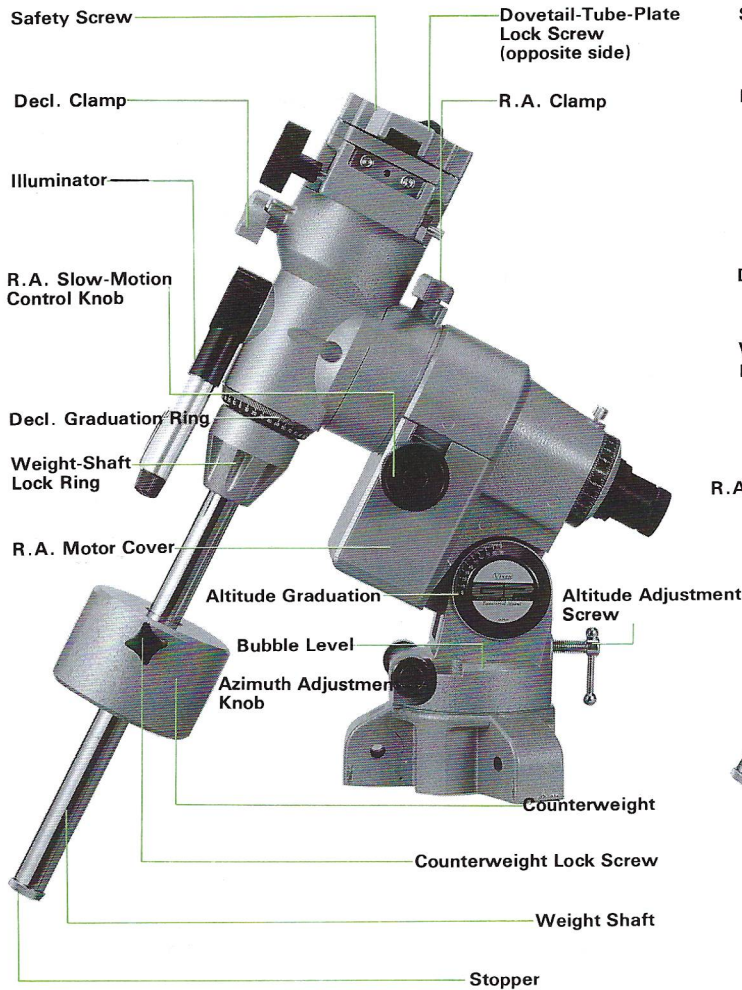

"GP-DX" Mount

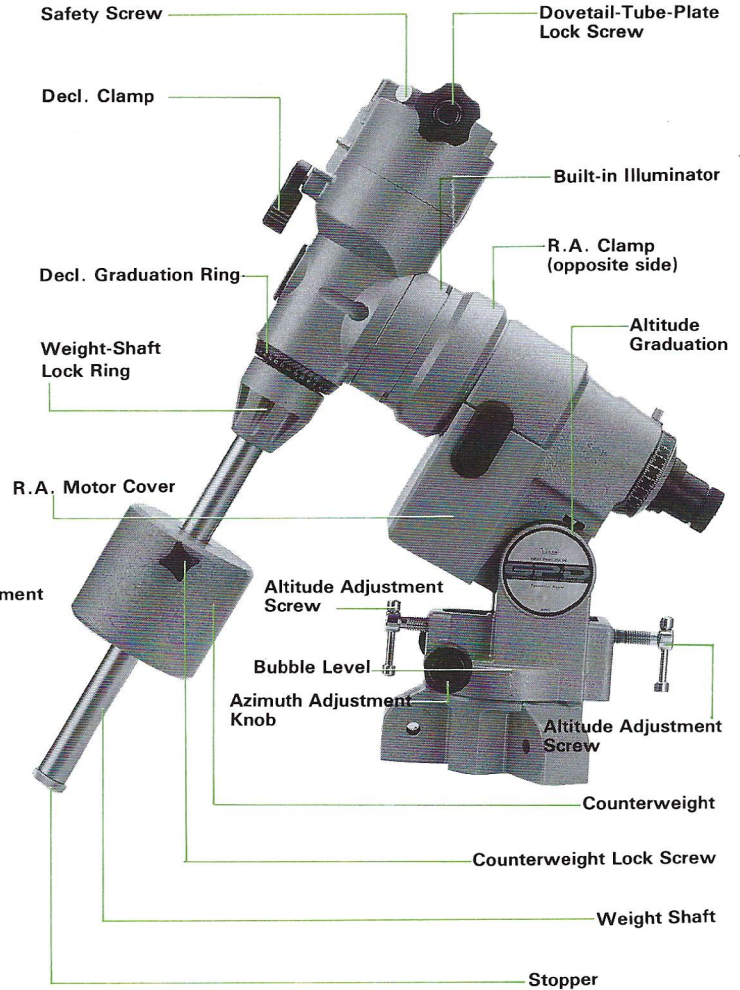

«Specifications of "GREAT POLARIS" Mount»

- R.A. and Decl. axes.....whole-circle micro-movement, 144-tooth worm gears
- R.A. graduation.....10' increment
- Decl. graduation.....2° increment
- R.A. slow-motion control knob.....attachable to either side, 2.5° per revolution
- Decl. slow-motion control knob.....attachable to either side, 2.5° per revolution
- Altitude adjustment.....0° to 62°, about 2° per revolution of adjustment screw
- Azimuth adjustment.....±5° about 1° per revolution of adjustment knob
- R.A. shaft.....maximum diameter 62mm
- Decl. shaft.....maximum diameter 62mm
- Weight shaft.....diameter 20mm
- Maximum loading weight.....about 7kg

«Polar Alignment Graduations»

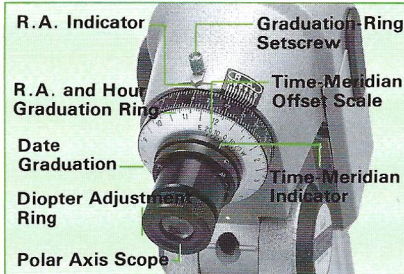

«Built-in Type Illuminator»

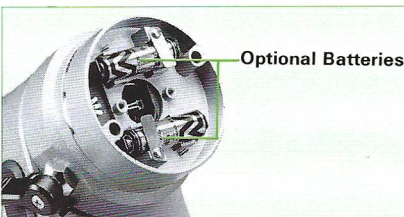

«Specifications of "GP-DX" Mount»

- R.A. and Decl. axes.....whole-circle micro-movement, 144-tooth worm gears
- R.A. graduation.....10' increment
- R.A. and Decl. motor drives.....±1.5x ±2x ±32x
- Altitude adjustment.....0° to 62°, about 2° per revolution of adjustment screw
- Azimuth adjustment.....±20°, about 1° per revolution of adjustment knob
- R.A. shaft.....maximum diameter 62mm
- Decl. shaft.....maximum diameter 62mm
- Weight shaft.....diameter 20mm
- Maximum loading weight.....about 10kg

FOR FIRST TIME TELESCOPE USERS

This manual will provide you with a better understanding of your new telescope—including its features, hardware and capabilities. As with many things, the better you understand the workings of the equipment, the more enjoyment you will get from it. This is particularly true of telescopes. So take a few moments now to become thoroughly acquainted with your new telescope. Mastering an astronomical telescope is a key to the success in astronomical observation.

Step 1 Proper assembly of the telescope

Pay particular attention to the following when assembling the telescope. Make sure extension clamps that fix the tripod legs and a fixing knob for the mount on the underside of the tripod head are firmly fastened. They provide the stability which is so important to quality observation.



Step 2 Installation of an eyepiece

① The magnification of your telescope is determined by the eyepiece you use. It can be computed with the following formula.

$$\text{Magnification} = \frac{\text{Focal Length of Objective (mm)}}{\text{Focal Length of Eyepiece (mm)}}$$

② Read the writing on the eyepiece, and you may find characters such as "K20mm", "HM12.5mm" or "LV5mm". The first letter represents the type of eyepiece design, the number that follows represents the focal length of the eyepiece. As the number gets smaller, the magnification power of the eyepiece becomes greater, thereby allowing the viewer to observe close-up detail.

③ Eyepieces are classified into three sizes of barrel diameter, 24.5mm, 31.7mm and 50.8mm.

④ To set a 24.5mm, 31.7mm or 50.8mm eyepiece, insert it in a proper 24.5mm, 31.7mm or 50.8mm eyepiece adapter and securely tighten the eyepiece setscrew.

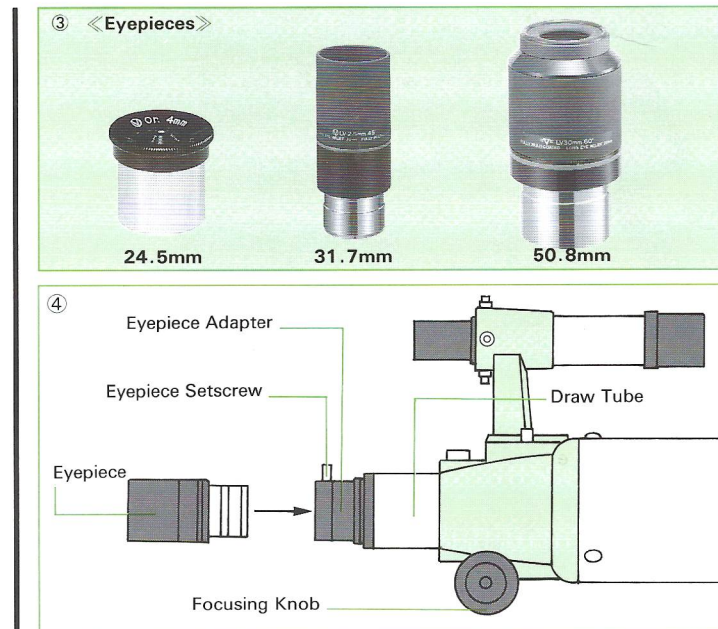

Step 3 First operation of the telescope

① Unfasten the R. A. and Decl. clamps and you can move the optical tube in a full range of motion.

CAUTION: DO NOT FORCE THE OPTICAL TUBE TO MOVE WHEN THE R. A. CLAMP OR DECL. CLAMP IS FULLY ENGAGED. THIS MAY DAMAGE PRECISION PARTS OF THE MOUNT.

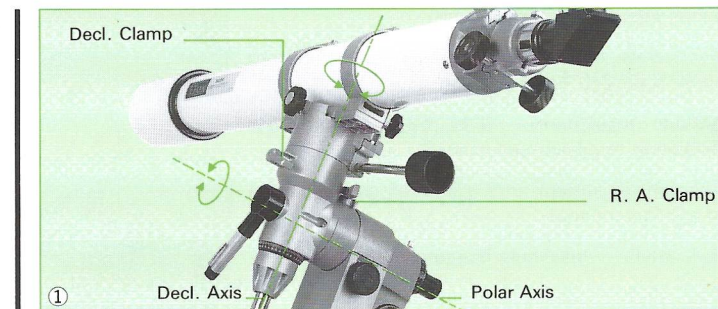

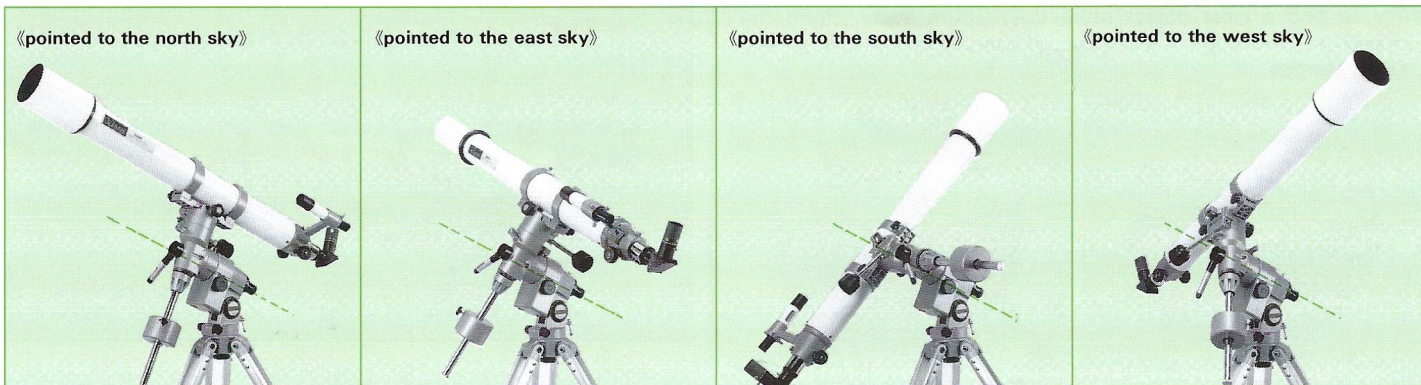

To eliminate undue stress on the mount, the telescope should be properly balanced after all the standard accessories (i. e., star diagonal, eyepiece, etc.) have been attached to the telescope. An unbalanced telescope may cause possible damage to the mount. In addition, proper balancing is crucial for accurate tracking if using a motor drive.

② To balance the mount, release the R. A. clamp and position the telescope off to one side of the mount. The counterweight bar will extend horizontally to the opposite side of the mount. Without tightening the R. A. clamp, gradually let go of the telescope to see which way it rolls. Loosen the counterweight and move it to a point where it balances the telescope. Re-tighten the counterweight.

③ The telescope should also be balanced on the declination axis to prevent any sudden motions when the Decl. clamp is released. To balance the telescope in Decl., release the R. A. clamp and rotate the telescope so that it is on one side of the mount (i. e., as described above for balancing the mount). Once this is done, lock the R. A. clamp to hold the telescope in place. Now, hold the telescope tube with one hand while releasing the Decl. clamp with the other. The telescope will most likely rotate around the declination axis. Slightly loosen the tube-ring screws and slide the telescope either forward or backward in the tube rings until it remains stationary when the Decl. clamp is released. Re-tighten the tube-ring screws.

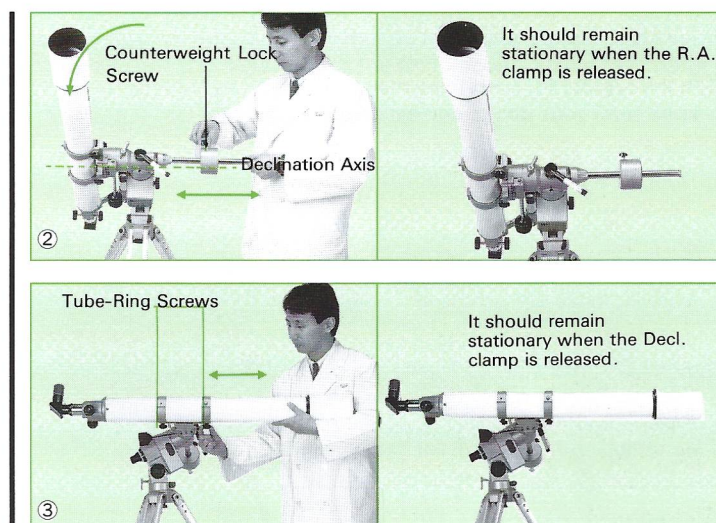

Step 4 Your first look

Your first look should be done in the daytime when it will be easier to locate adjustment knobs and clamps. This will help to familiarize you with your telescope, thus making it easier to use at night.

- ① Attach a low-power eyepiece having a long focal length. A high-power eyepiece having a short focal length will make the field of view darker and will make it more difficult to bring into focus.
- ② Remove lens caps from the objective and eyepiece.
- ③ Look through your telescope.

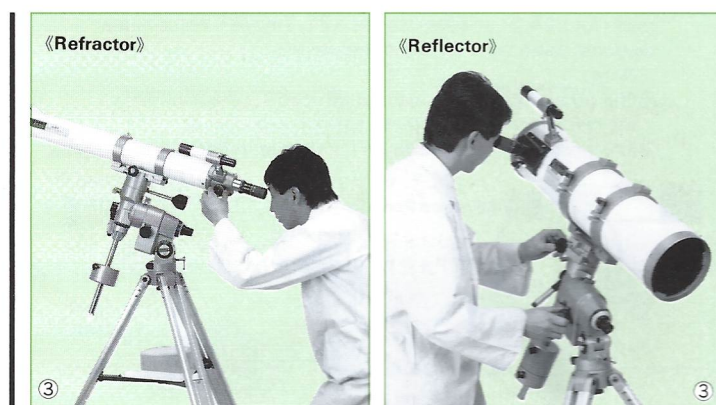

④ Try to find a clear object more than 200m away. Point the telescope toward the object after unfastening both the R. A. and Decl. clamps.

[Note] Eyepiece angle can be adjusted for your telescope by rotating the optical tube in the tube rings after unfastening the tube-ring screws.

⑤ In the beginning, everything may blur. Gradually turn the focusing knob until your object comes into sharp focus.

⑥ Whoops! The view is upside down, and backward! But that's OK—all astronomical telescopes operate this way as it really doesn't matter in space. There are special prisms that correct the condition, but they dim the image slightly.

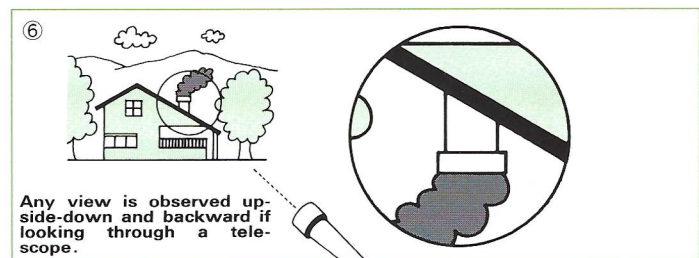
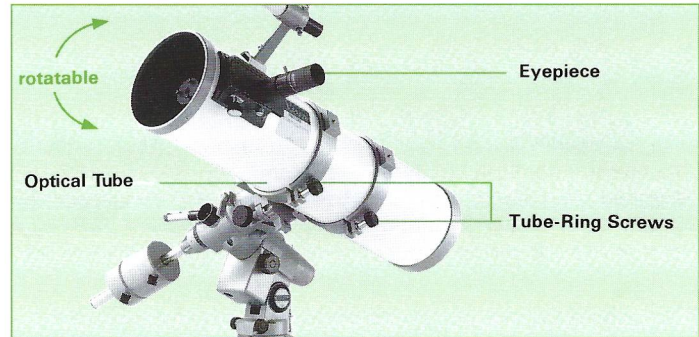

《How to use a Porro Prism or 45° Erect-Image Diagonal Prism》

To correct the upside-down view on the refractors, use a 36.4mm porro prism or 24.5mm 45° erect-image diagonal prism for a 24.5mm eyepiece and a 31.7mm 45° erect-image diagonal prism for a 31.7mm eyepiece.

[Note]

- ① The other porro prisms cannot be used for this purpose on the refractors because these cannot close focus.
- ② Any prism cannot be used on Newtonian reflectors.

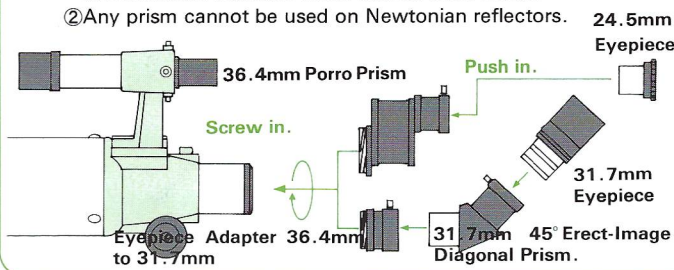

《How to use a Terrestrial Eyepiece》

Although the upside-down view can be corrected with a terrestrial eyepiece, it makes the field of view narrow. Also, the magnification power of the terrestrial eyepiece cannot be changed. The method of calculating the magnification of the terrestrial eyepiece is the same as those of other eyepieces. [Note] The terrestrial eyepiece cannot be used on Newtonian reflectors.

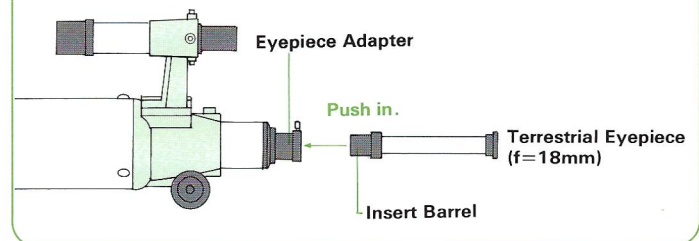

Step 5 Changing eyepieces

① To remove the eyepiece, loosen the eyepiece setscrew and slide the eyepiece out. Slide the chrome barrel of a higher-power eyepiece into the eyepiece adapter and re-tighten the setscrew to hold the eyepiece in place.

[Note] As the high-power eyepiece makes it more difficult to bring into focus, turn the focusing knob slowly and carefully.

② The size of the image you now observe through the telescope is larger.

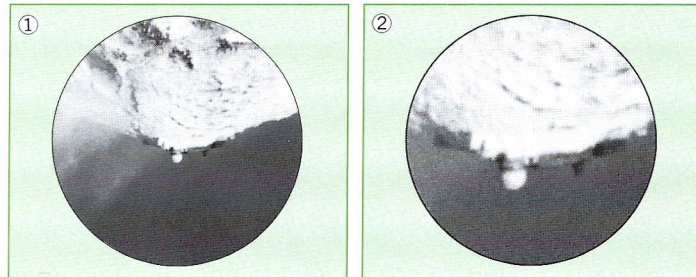

Step 6 Use of the finderscope

How does a terrestrial view look through a finder? Upside-down and backwards—just as through the main telescope. However, there are points of slight difference.

(a) A crosshair reticle is seen. This is for pinpoint accuracy.

(b) A wider view is seen than when the main telescope is used.

The finderscope is simply to help you easily locate objects and bring them within the view of the main telescope. As your telescope—even on “low” power—is still extremely powerful, finding the objects can be difficult. This is why telescopes are equipped with finderscopes.

Prior to serious observations, make sure both the telescope and the finderscope are aligned—targeted on the same object. If the same object is not centered in the crosshairs of the finderscope and centered in the main telescope, adjust the finderscope, using the position setscrews.

«Aligning the Finderscope»

① Attach a low-power eyepiece to the eyepiece adapter of your telescope.

② Point the telescope at a clear object about 1km away and center it in the field of view.

③ Bring the same object to the center of the crosshairs of the finderscope, using the position setscrews.

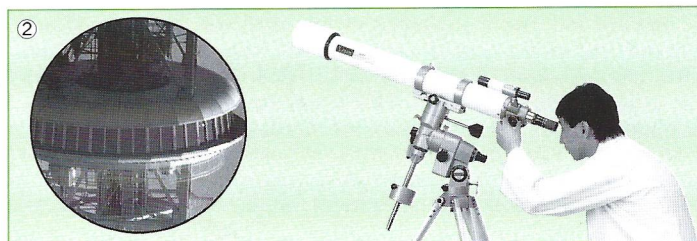

«How to align the Finderscope»

① and ② show how to fasten the finderscope with the position setscrews.

Position Setscrews (3 pieces)

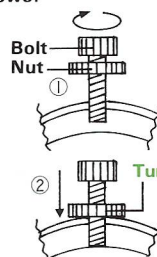

Turn and fix the nut.

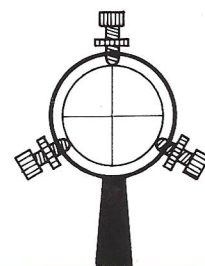

Step 7 Your first observation—the Moon!

Now, you are ready to point the telescope toward celestial objects! Although observation may start with any celestial object, it is advisable to start with the brightest objects first and work your way to fainter ones. Here is a good beginner's viewing order:

1. Moon
2. Jupiter
3. Saturn
4. Sun (with proper filter)
5. Venus
6. Mars
7. Mercury
8. Multiple Stars
9. Nebulae and Star Clusters

Now, let's look at the Moon.

- ① Locate the Moon in the finderscope and center it on the crosshairs.
- ② Put a low power eyepiece in the telescope. At low power (about 50 magnification), you will be able to see the entire lunar disk at one time.
- ③ If you later desire a close-up of a lunar region, use a higher power eyepiece.
- ④ Keep in mind that the rotation of the earth will cause the Moon to drift out of the field of view. You will have to manually adjust the telescope using the R. A. and Decl. slow-motion control knobs to keep the Moon centered. This effect will be more noticeable at higher power.

[Note] One of the best times to observe the Moon is during its partial phases. Long shadows reveal a great amount of detail on the lunar surface.

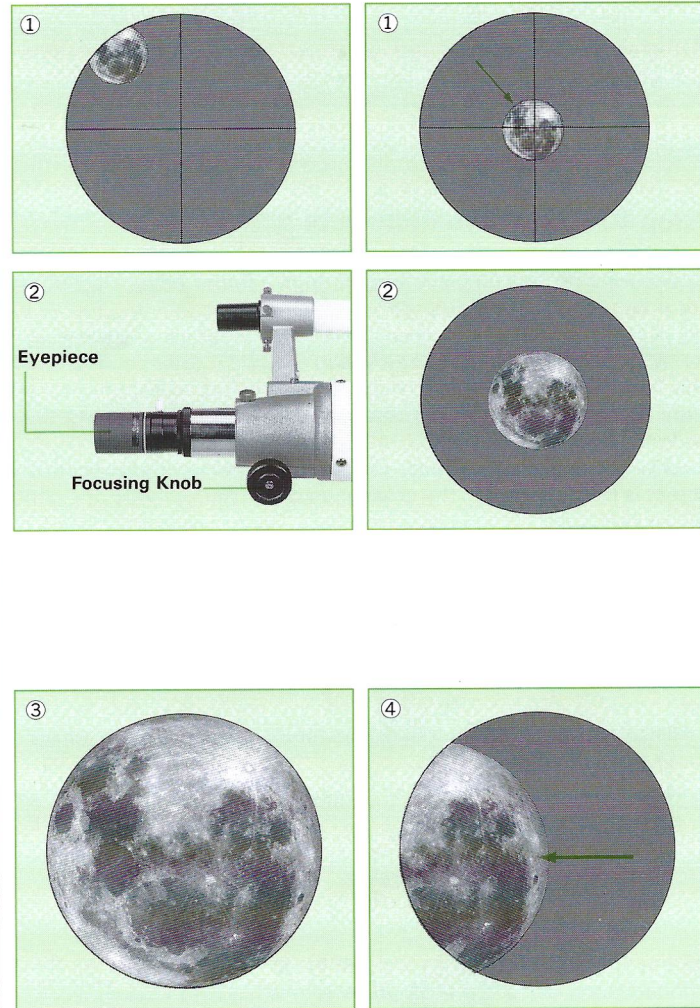

«How to use a Moon Filter»

If you find that the lunar image is too bright for comfortable viewing, attach a moon filter to the eyepiece. It will reduce the brightness and, at the same time, increase contrast on the lunar surface.

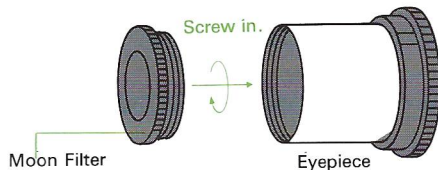

«How to use a Diagonal Prism»

A diagonal prism lets you view objects at a right-angle (90°) from the direction where the refractor telescope is pointing, thereby allowing comfortable viewing when the telescope is pointed at or near the zenith (directly overhead). Newtonian reflectors do not require such a diagonal prism since objects are always viewed from the side of the main tube of the telescope.

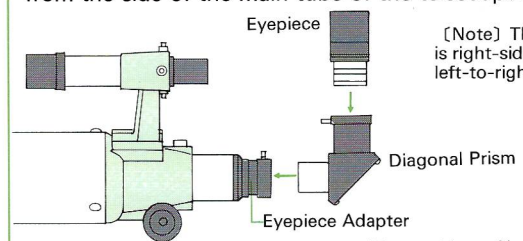

(Not usable on Newtonian reflectors)

Step 8 Observing Jupiter and Saturn

Planets such as Jupiter and Saturn appear to steadily move across the sky from east to west. They appear as bright stars. Most astronomy publications tell where the planets can be found in the sky each month.

① Use a low power eyepiece—about 50 magnification. Jupiter will be seen like a small disk. You will also be able to see four moons of Jupiter. (These satellites are not always visible because their orbits carry them behind the planet.) Saturn, with its beautiful rings, is easily visible.

② When seeing conditions are good (the atmosphere is steady), raise the magnification greater than 100. You will be able to see the cloud belts of Jupiter and the great Red Spot (if it is visible at the time you are observing). The rings of Saturn and even the small dark division (Cassini's Division) in the rings will be visible.

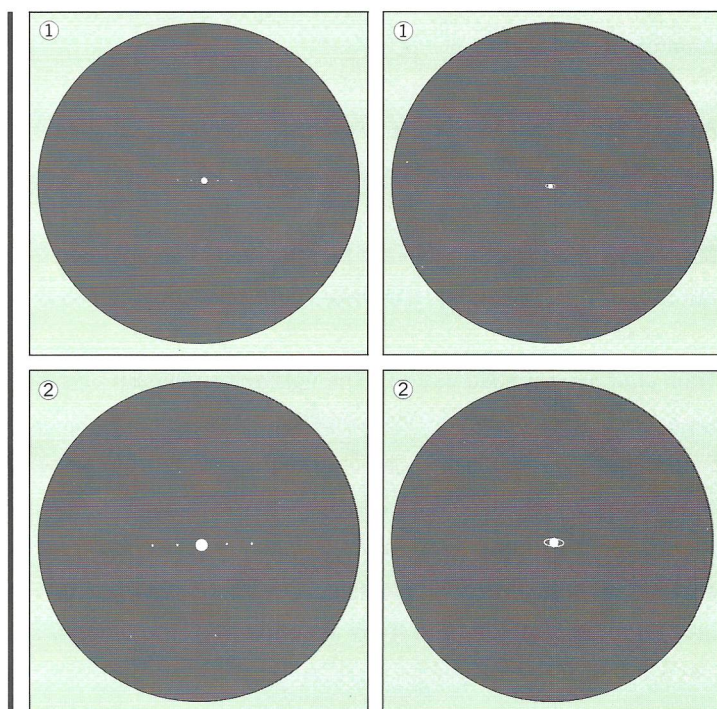

Step 9 Observing the Sun

CAUTION: NEVER POINT A TELESCOPE AT THE SUN AND NEVER LOOK DIRECTLY AT THE SUN WITHOUT TAKING ALL PROPER PRECAUTIONS. READ THIS PARAGRAPH CAREFULLY BEFORE UNDERTAKING ANY SOLAR OBSERVATION.

All telescopes collect light—much more light than the human eye. Therefore, viewing the Sun through a telescope must only be undertaken carefully, with all proper precautions observed. Failure to take the proper precautions may result in permanent blindness and damage to your telescope. To observe the Sun safely, always fit the eyepiece with a sun filter. In addition, always place the objective cap on the telescope with only the small solar aperture open. You will enjoy seeing sun spots—huge nuclear sun storms that constantly change position and size.

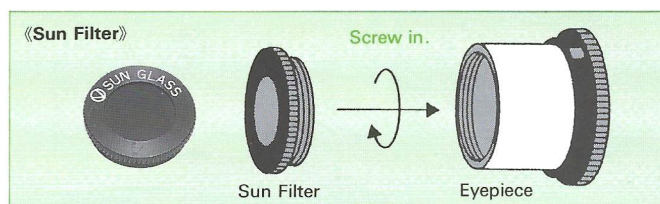

«Using the Sun Diagonal Prism»

When the sun filter is used with the telescope for long observation, it may sometimes break from the heat. If a sun diagonal prism is added, it exhausts 96% of sunlight and heat outside, so that only the remaining 4% of sunlight is used to observe the Sun, allowing long observation with safety. A special sun filter to be screwed in the eyepiece belongs to the sun diagonal prism. Use the special sun filter together with the sun diagonal prism. Its colour density is somewhat lighter than the ordinary sun filter. Only when using the sun diagonal prism and the special sun filter, take off the objective lens cap to expand the effective diameter of the objective lens and to enhance its resolving power.

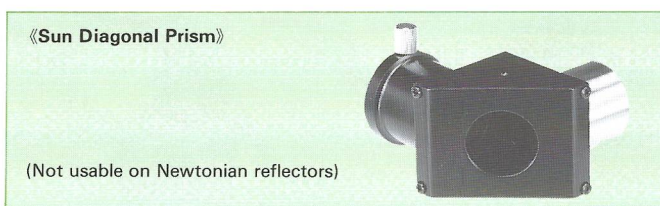

Step 10 General Cautions

- ① Try never to view through glass windows when observing. Clear as window glass seems, compared to the fine optical glass of your telescope, it produces very distorted images. If the observation is undertaken through an open window, air movement through the window (owing to the temperature difference between the inside and outside air) may cause image instability, resulting in distortion.
- ② Be sure the optical axis of the telescope is centered. If the optical axis of the telescope is out of center, the image of an object is lengthened or is unnecessarily coloured.
- ③ Stars other than the Sun can not be observed in an enlarged image, because they are very far from the earth as compared with the Sun or other planets. However, your telescope can show you millions of stars not visible to the naked eye.
- ④ Train your eye for observation. The figure of a celestial object observed through a telescope looks different depending upon the experience of the observer. With repeated observation experience, you will begin to see objects that you could not earlier observe. Sometimes averted vision—glancing slightly away from an object will help you see more detail.
- ⑤ Stars appear to move very fast. Because a telescope tracks an object at high magnification for observation, the apparent movement of an object seems rapid. For instance, when observing Jupiter at a magnification of 100, the moving planet takes only about one minute and thirty seconds from the time when it first appears in the eyepiece to the time when it disappears. We call this apparent motion because most of the motion is really the earth rotating under us!

«Newtonian Reflector»

Secondary-Mirror Support Arm and Adjustment Screws

The secondary mirror is of critical importance to the proper operation of your telescope. Never turn the adjustment screws except when you correct the optical axis.

When observing an object soon after taking the telescope outside, you can sometimes see the object appear to fluctuate. This is because warm air and cold air are mixing in the tube. If possible, expose the telescope to the open air for 20 to 30 minutes before observing, so that tube temperature stabilizes.



Primary-Mirror Cell

There are three pairs of screws on the back of the primary-mirror cell. Never turn these screws except when you correct the optical axis.

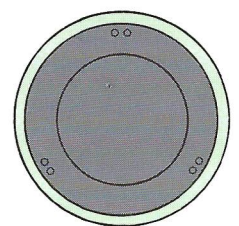

HOW TO SET UP THE EQUATORIAL MOUNT TELESCOPE

The stars appear to move across the sky. For observers in the northern hemisphere, all stars appear to move around the north celestial pole. For observers in the southern hemisphere, all stars appear to move around the south celestial pole. This motion is caused by the Earth's rotation about its axis. To have your telescope track the stars as they move across the sky, the telescope's axis of rotation must be made parallel to the Earth's axis.

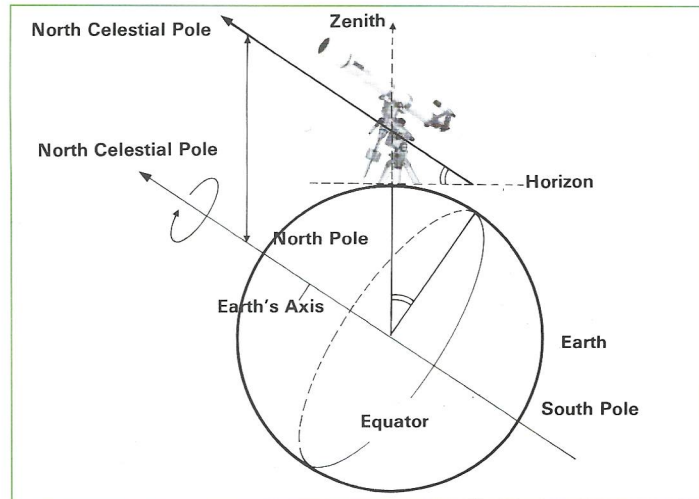

Roughly Aligning the Polar Axis of the Telescope

The following simple alignment of the polar axis is good enough for just observing an object—but not accurate enough for prolonged observation or astrophotography.

- ① Find out the latitude of your location referring to a map, etc.
- ② Set the altitude graduation to the latitude of your location with the altitude adjustment screw turned.
- ③ Set the polar axis of the telescope towards the north. With a compass, you can do it easier.

The following is to make a more precise alignment when Polaris can be seen.

- ① Unfasten the Decl. clamp and turn the optical tube until it is nearly at right angles to the polar axis.
- ② Take off the polar axis cap. Look through the polar axis scope and bring Polaris in its field of view by adjusting the azimuth and altitude with the azimuth adjustment knobs and altitude adjustment screw. If the polar axis scope is not available on your telescope, look through the polar axis hole and bring Polaris in the view.

[Note] When turning the azimuth adjustment knobs, always unfasten one adjustment knob before tightening the other adjustment knob.

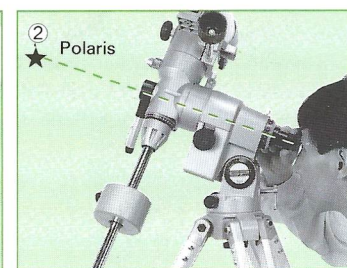
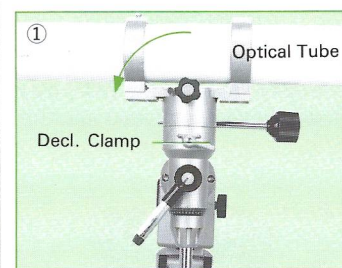
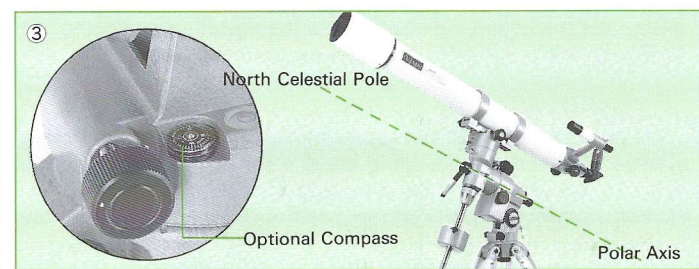
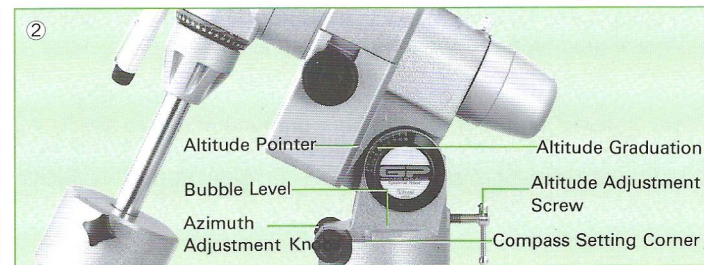

《Optional Compass》

There is a compass setting corner on the mount. On the corner, set the optional compass with its needle parallel to the polar axis. The compass is useful to find the north direction.

Using Your Polar Axis Scope in the Northern Hemisphere

- ① In the Northern Hemisphere, locate Polaris in the sky and point the polar axis of the mount in the direction of Polaris.
- ② Adjust the tripod legs until the bubble level on the left side of the mount indicates the tripod is level. (An optional tripod-leg adjuster makes the adjustment easier.)
- ③ Install the polar axis scope illuminator onto the front of the polar axis and turn on the switch. (Refer to the paragraph «How to use a Polar Axis Scope Illuminator».)
- ④ Unfasten the Decl. clamp and turn the optical tube until it is nearly at right angles to the polar axis. If you do not do this, the polar axis scope will be shaded with the Decl. axis and can not be used.
- ⑤ While looking in the polar axis scope, adjust the diopter adjustment ring to focus on the reticle in the field of view.
- ⑥ Look at a map or atlas that shows the longitude of your observing site. Once you know your longitude, find the difference between that and the standard time meridian for your zone. Set the difference on the time meridian offset scale. If your observing site is located in the east of the standard time meridian, set the E side graduation to the time meridian indicator. If in the west, set the W side graduation to the time meridian indicator.
- ⑦ Set "0 hour" on the R. A. and hour graduation ring to the R. A. indicator after loosening the graduation-ring setscrew. Re-tighten the graduation-ring setscrew. (The graduation-ring setscrew should be loosened when observing.)
- ⑧ Unfasten the R. A. clamp and turn the telescope around the polar axis to set the observing date on the date graduation ring to the observing time on the R. A. and hour graduation ring.
- ⑨ Look through the polar axis scope and bring Polaris in the Polaris circle of the reticle by adjusting the azimuth and altitude with the azimuth adjustment knobs and altitude adjustment screw. The Polaris circle indicates the correct position of Polaris relative to the celestial pole.
- ⑩ Owing to a wobble in the earth's axis, the position of Polaris changes gradually over time. The diagram ⑩ shows the position of Polaris through the year 2005. In order to align the polar axis more precisely, put Polaris on the position indicated on the diagram.

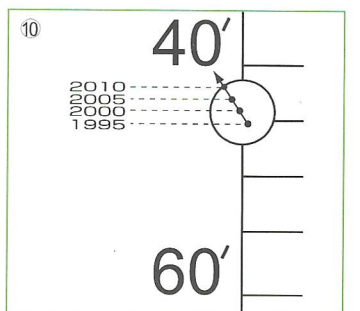
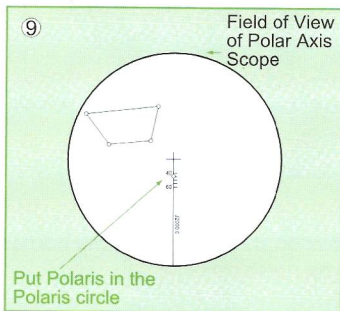
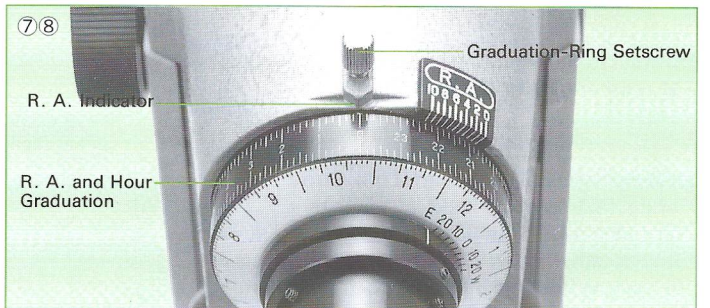
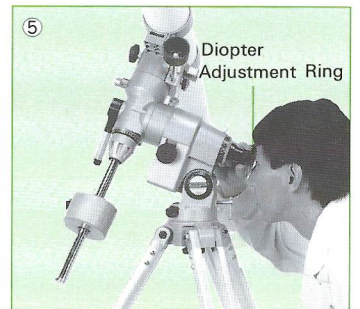
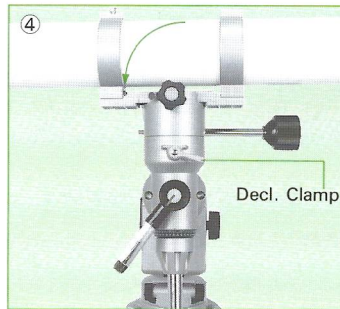
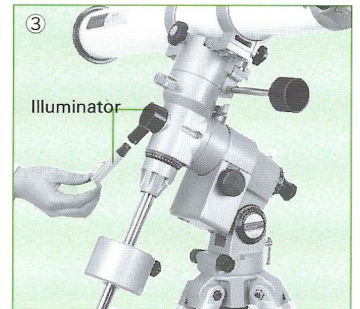

Using Your Polar Axis Finder in the Southern Hemisphere

The polar axis scope also contains a reticle for the southern hemisphere. The reticle shows the relative positions of four stars near the south celestial pole. The stars are Sigma (σ), Tau (τ), Chi (χ) and Upsilon (ν) of Octantis.

- ① Point the polar axis of the mount toward Octantis.
- ②~⑤ Refer to the instructions described for using in the northern hemisphere.
- ⑥ While looking through the polar axis scope, adjust the mount in altitude and azimuth or rotate the polar alignment reticle until the four stars mentioned above are in the respective circles on the reticle. The polar alignment reticle is rotated by moving the telescope in right ascension.

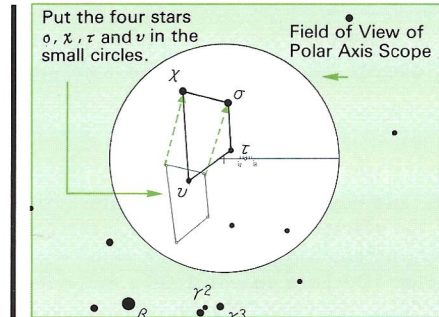

Octantis

Star	Magnitude
σ	5.5
χ	5.2
τ	5.6
ν	5.7

«How to use a Polar Axis Scope Illuminator»

- ① The illuminator is installed on the front of the polar axis. When turning on the penlight switch, the field of view of the polar axis scope is illuminated in dim red so that the polar alignment reticle can be seen clearly. The penlight can be switched on by turning its switch either way.
- ② When polar alignment is completed, remove the illuminator.
- ③ The penlight is also useful as a map light when looking at a star chart, etc.

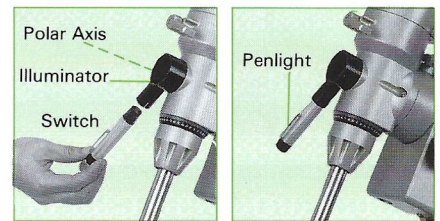

Aligning the Polar Axis Scope

The polar axis scope is installed and aligned at the factory. If the adjustment screws are loosened or if the mount is jarred severely, the polar axis scope may have to be realigned. The optical axis of the polar axis scope must be made parallel to the rotational (R. A.) axis of the mount and the Polaris circle which indicates the proper position of Polaris relative to the pole must be set to the R. A. and hour graduation and date graduation.

[How to know if the optical axis of the polar axis scope is parallel to the rotational axis of the mount]

- ① Remove the optical tube, counterweight shaft and counterweight from the mount. Release the R. A. clamp and rotate the mount head until it is on the right side of the mount.
- ② Find an object in excess of 1km away and center it in the field of view.
- ③ Release the R. A. clamp again and rotate the mount head so that it is on the left side of the mount.
- ④ If the optical axis of the polar axis scope is parallel to the rotational axis of the mount, the object will be kept at the center. If not, it will move off center as shown on the illustration.

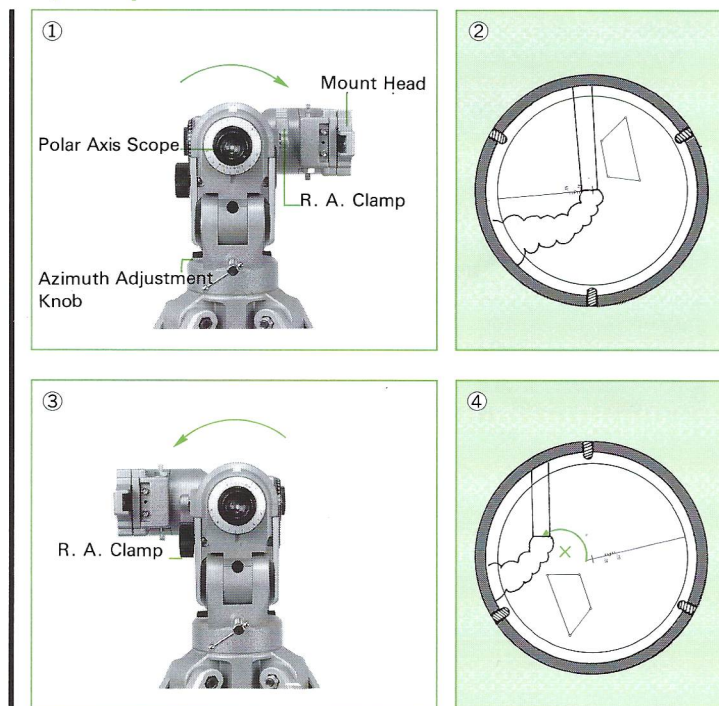

[How to set the Polaris circle to the R. A. and hour graduation and date graduation]

- ① Incline the polar axis by turning the altitude adjustment screw so that it is parallel to the ground.
- ② Release the R. A. clamp and rotate the polar axis until the Polaris circle on the reticle is directly below. (Ignore the southern hemisphere reticle.)
- ③ Fasten the R. A. clamp.
- ④ Set "0 hour" on the R. A. and hour graduation ring to the R. A. indicator after loosening the graduation-ring setscrew. Re-tighten the graduation-ring setscrew. Turn the date graduation ring until October 10th lines up with 1:00 a.m. on the R. A. and hour graduation ring. (At this time on this date, Polaris is at upper culmination.)
- ⑤ Loosen the setscrew that secures the ring with the time meridian indicator. Turn the ring until the time meridian indicator points to the "0" mark on the time meridian offset scale. Re-tighten the setscrew.

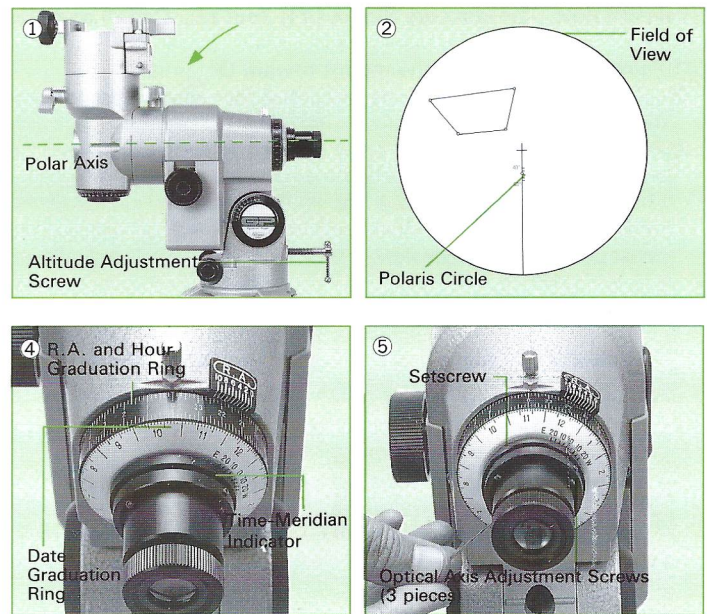

[How to make the optical axis of the polar axis scope parallel to the rotational axis of the mount]

- ① Release the R. A. clamp and rotate the mount head until it is on the right side of the mount.
- ② Find an object in excess of 1 km away and center it in the field of view. (The optical axis is at the center of the field of view.)
- ③ Rotate the mount head again so that it is on the left side of the mount. The object originally seen at the center will describe a semicircle around the point where the mechanical axis is pointing and will move off center.
- ④ Determine how far and in what direction the optical axis moved from the mechanical axis. By turning the optical axis adjustment screws, move the optical axis toward the point where the mechanical axis is pointing. Keep in mind that the image in the polar axis scope is inverted.
- ⑤ Repeat this process until the optical axis of the polar axis scope is centered on the rotational axis of the mount. When properly aligned, the object remains centered while rotating the mount.

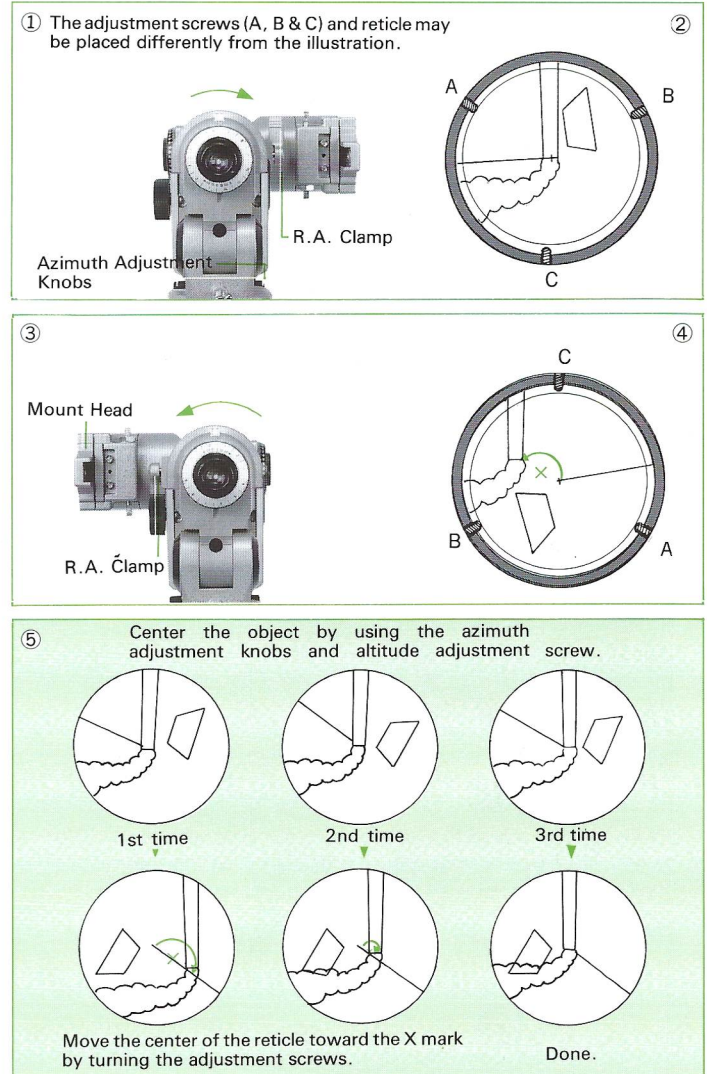

HOW TO USE THE R.A. AND DECL. GRADUATION RINGS (SETTING CIRCLES)

The R.A. and Decl. graduation rings (setting circles) are helpful to search for faint nebulae and clusters which are hard to be found with the naked eye. To make a search with the graduation rings, you first have to locate a bright star near the object you want to observe. The following is an example on how to use the graduation rings.

Example: Finding the Ring Nebula, M57

From the star atlas, you will see that the Ring Nebula, M57, is close to the star Vega. Vega is a bright star of magnitude 1 and can be seen from Spring to Autumn in most places. Let's use Vega as a base to find M57. (The telescope must be polar aligned.)

- Find the coordinates (right ascension and declination) of Vega and M57 in a book or star atlas.

	R.A.	Decl.
Vega	18h36m	39°
M57	18h52m	33°

- Center Vega in the field of view of the telescope using a low-power eyepiece (under 50X).
- Turn the R.A. graduation ring and set it to 18h36m (18 hours 36 minutes).
- Set the Decl. graduation ring to 39 degrees.
- To have the telescope moved to M57, turn the R.A. slow-motion control knob or drive the R.A. motor until the R.A. and hour graduation ring is set to 18h52m.
- Turn the Decl. slow-motion control knob or drive the Decl. motor until the Decl. graduation ring is set to 33 degrees.
- The Ring Nebula can now be seen in the field of view. But, it may be very small. Try to use a higher-power eyepiece.

How to use the Verniers

If you use the verniers, the R.A. and Decl. graduations can be set more precisely.

- Reading the R.A. graduation with the vernier

On the right example, the vernier graduation 0 is positioned between 22h0m and 22h10m. The R.A. graduation and vernier graduation coincide at the vernier graduation 4. Then, the R.A. graduation is read as 22h4m (22h0m+4m).

- Reading the Decl. graduation with the vernier

The vernier graduation 0 is in the middle of the Decl. vernier. Use the vernier graduation in the increment direction of the Decl. graduation. On the right example, the vernier graduation 0 is positioned between 48° and 50°. As the Decl. graduation is incremental to the left side, use the left side vernier graduation. The Decl. graduation and vernier graduation coincide at the vernier graduation 1° 30'. Then, the Decl. graduation is read as 49° 30' (48° + 1° 30').

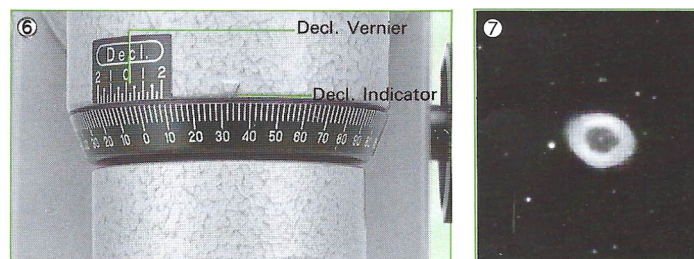
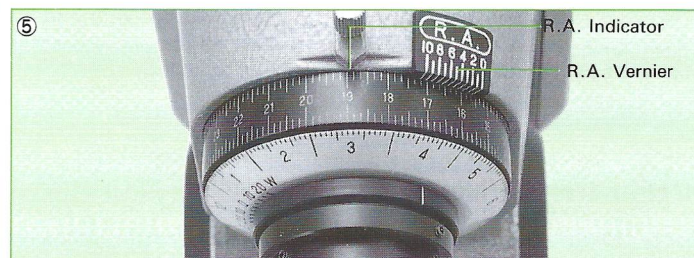
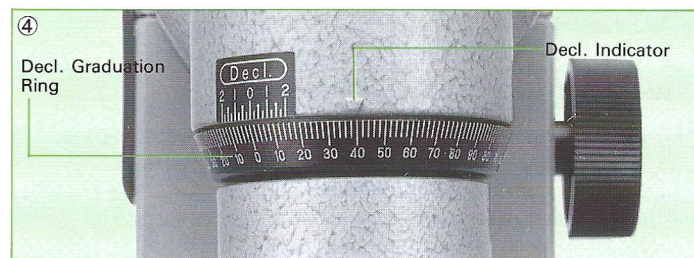
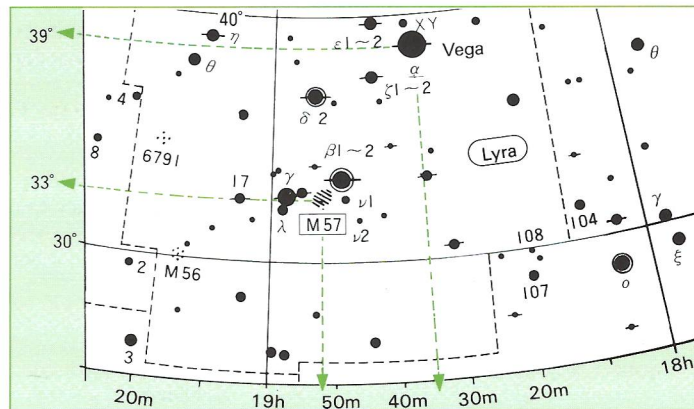

Example

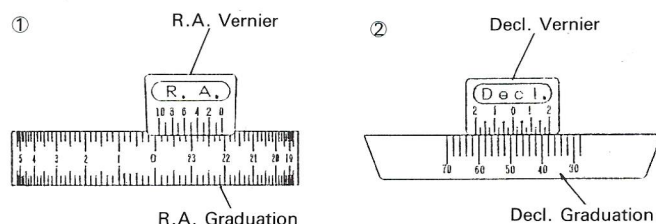

HOW TO COLLIMATE THE OPTICAL SYSTEM OF A NEWTONIAN REFLECTOR

The optical performance of your telescope is directly related to its collimation. Your Newtonian reflector was collimated at the factory before shipment. However, if the telescope is roughly handled or jarred severely, it may have to be collimated.

Checking the Collimation of Your Telescope

Look at a bright star through the telescope. If the star is seen as a small dot at the center of the field of view, it is collimated correctly. You can also check the collimation by getting out of focus a little to enlarge the image. See the illustrations.

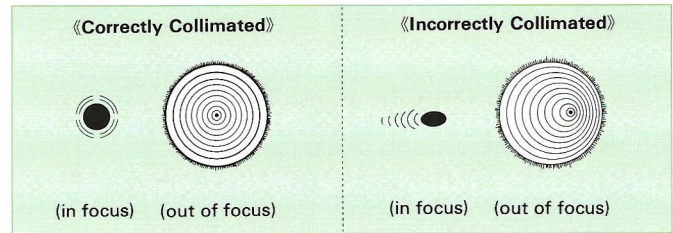

Adjusting the Secondary Mirror

Point the telescope toward a brightly lighted area and look into the draw tube without attaching any eyepiece. If it looks like the diagram (right), both the primary and secondary mirrors need adjustment. First, adjust the secondary mirror. Loosen three adjustment screws on the secondary mirror holder. Adjust the aspect of the secondary mirror so that it faces toward the draw tube correctly, and center the reflection of the primary mirror in the secondary mirror with the three adjustment screws while fastening.

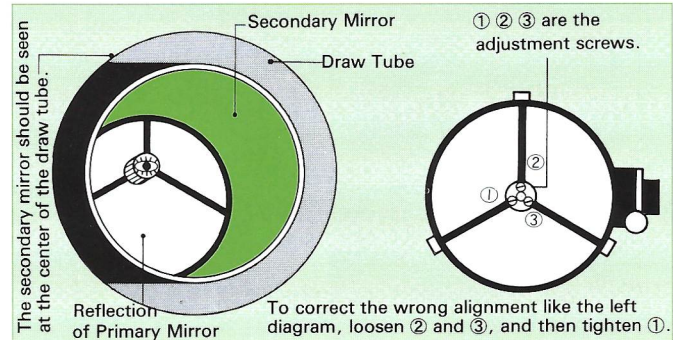

Adjusting the Primary Mirror

If the reflection of the secondary mirror is not centered like the diagram (right), the primary mirror needs adjustment. There are three pairs of adjustment screws behind the primary mirror frame. One of the pair screws is for pushing adjustment and the other is for pulling adjustment. Loosen one first and then tighten the other to take up the slack. With these adjustment screws, center the reflection of the secondary mirror in the primary mirror. If you hold out your hand on the opening of the tube so that it is reflected on the primary mirror, you will quickly find which screws should be adjusted.

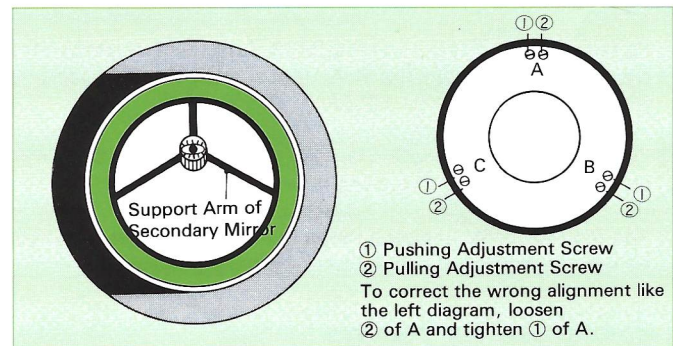

Collimated Optical System

On the collimated optical system, you can see a set of concentric circles with the reflection of your own eye in the middle when looking into the draw tube. See the diagram. It would be difficult to have the optical system collimated perfectly the first time. It becomes easier with practice.

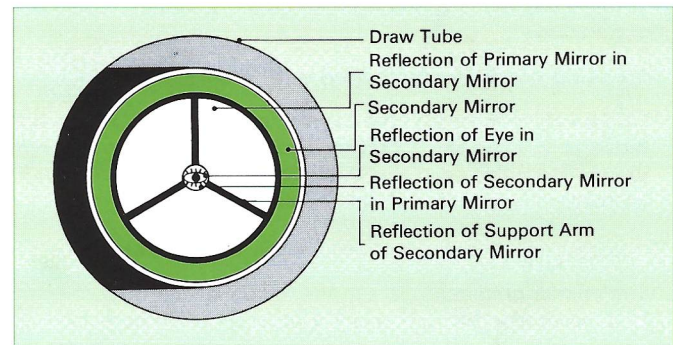

CAMERA ADAPTERS

A camera adapter allows you to attach your camera to the draw tube of your telescope. Optional 36.4mm and 43mm camera adapters are offered. Select what fits your telescope.

Components of the Camera Adapters

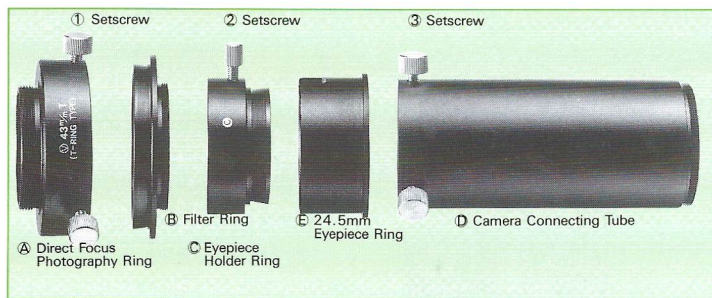

Attaching the Camera Adapters

When attaching the camera adapters, keep in mind the following.

- To attach the 36.4mm camera adapter to a 36.4mm draw tube, an eyepiece holder has to be removed from the draw tube. To a 43mm draw tube, the 36.4mm camera adapter can be attached after removing an eyepiece holder from the draw tube, and the 43mm camera adapter can be also attached if a 43mm adapter ring is removed further from the draw tube. If you use the larger 43mm camera adapter on the 43mm draw tube, the edges of a photograph will be less darkened.
- For a 24.5mm draw tube, use an optional 24.5mm adapter and attach the 36.4mm camera adapter to it.
- An optional T-ring is needed to couple your 35mm camera body to the 36.4mm or 43mm camera adapter. Attach the proper T-Ring for your camera (see below).

Direct Focus Photography

- Mount the A direct focus photography ring on the draw tube.
- Mount the camera body to the B filter ring with the proper T-ring.
- Insert the camera body into the A direct focus photography ring and lock it with the 1 setscrew.
- Filters on the market can be mounted to the B filter ring. The 36.4mm camera adapter accepts one 34mm or 40.5mm filter and the 43mm camera adapter accepts one 49mm filter.
- If you use a filter when taking black and white photographs of the Moon or planets, the contrast will be improved. Photographic exposure times will be increased using the filters. The filters listed below are commonly used for astrophotography.

Code	Colour	Object
Y-2	Yellow	Moon, Venus
G-1	Green	Sun (coming close to the horizon)
R-1	Red	Sun, Mars

- To change the photographic angle, rotate the camera after loosening the 1 setscrew or the 2 setscrew.

Note: In case of the direct focus photography with a Newtonian reflector, remove the extension tube from the draw tube, or it can not be focused.

Telescopic Photography

- Mount the A direct focus photography ring on the draw tube.
- Screw the C eyepiece holder ring onto the B filter ring.
- Insert the coupled B and C into the A direct focus photography ring and lock them with the 1 setscrew.
- When using a 31.7mm eyepiece, insert it into the C eyepiece holder ring and lock it with the 2 setscrew.
- When using a 24.5mm eyepiece, insert the E 24.5mm eyepiece ring into the C eyepiece holder ring first and then insert the eyepiece into the E 24.5mm eyepiece ring. Lock it with the 2 setscrew.
- Attach the D camera connecting tube to the camera body with the proper T-ring.

Note: In case of the telescopic photography with a Newtonian reflector, attach the extension tube to the draw tube, or it can not be focused.

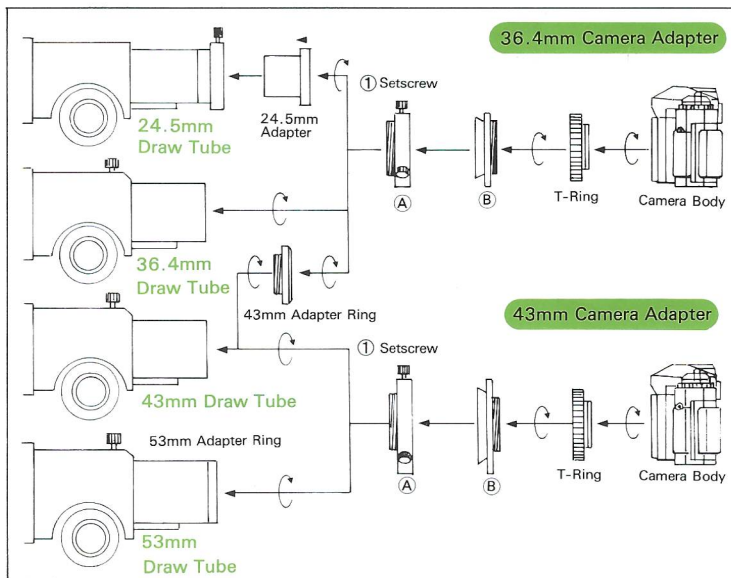

Note: For the refractors 80M, 90M, 102M, FL70S, FL80S, FL90S and FL102S, the 43mm camera adapter is recommended not to darken the edges in the photograph.

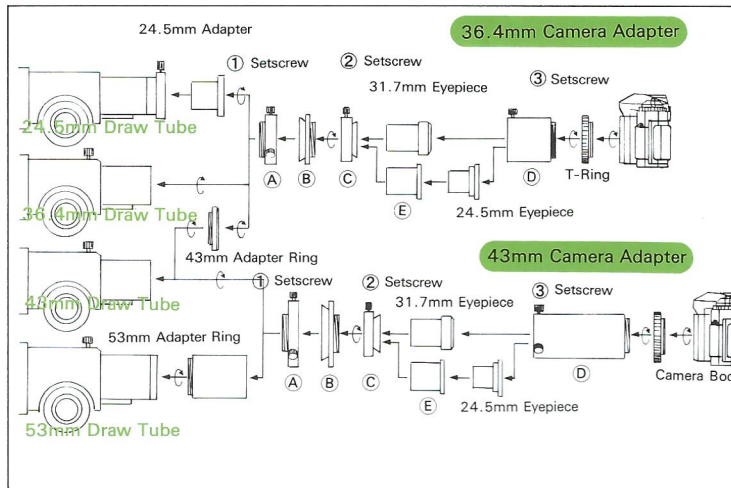

T-Rings

The T-ring couples your 35mm camera body to the camera adapters.

T-RING TYPE	CAMERA MODELS
Nikon	F2-Photomic, F2-Photomic (A, AS, SB), F2, F3, FE, FM, EM, Nikomat (EL, EL2, FT, FT2, FT3.), FE2, New FM2, FG, FG-20, FA, F4, F4S, F4E, F801S, F-801, F-601, F-601M
Canon	AE-1, EF, A-1, AV-1, F-1, FTb, FT, T80, T70, T50, AE-1 Program, T90
Minolta	X-1, XG-(S, E), XD, XD-S, X-7, XE, SR505, SR101, SRT Super 101, X-700, X-600, X-500
Olympus	OM (1, 2, 3, 4, IN, 2N, 10, 20, 30, 40, 101)
Pentax K	ME, MX, K2, KX, KM, MV-1, LX, Super A, AE-F, ME Super, MG, A3 Date, SFXW, SF7, P30N, Ricoh (XP-P, XR-3, XR-7, XR500 Auto, XR-1, XR-2, XR-500), VX-1
Konica	FS-1, ACOM-1, T3, FTA, New (T3, FTA), TC-X

T-RING TYPE	CAMERA MODELS
Contax	RTS, 139 Quartz, 137MD Quartz, 137MA Quartz, 167MT, 159MMRTS Quartz, FR-1, FR-II, FX-D Quartz, FX-3, RTS-III
Practica (thread mount)	Pentax (ES, ES-II, SPF, SP-II), Yashica (Electro X, TTS, FFT), Fujica (ST90, 801, 701, 605), Mamiya (Secor 500DTL, 1000DTL, MSX500), Ricoh (TLS401, TL-S, XR-10M, Auto), Petri MF-1, Practica LLC
Minolta α	α5000, α7000, α9000, α7700i, α8700i, α5700i, α3700i
Yashica AF	Kyosera (230-AF, 210-AF)
Canon EOS	EOS (650, 620, 1HS, 1, 10QD, 1000QD, 630QD, 700QD, RT)
T-C Ring (for camcorder)	Sony EVC-X10 CCD Camera Canon C1-20R

MOTOR DRIVES

Motor drives allow you to track celestial objects easily. There are two types of optional motor drives. One is a single-axis motor drive and the other is a dual-axis motor drive.

Single-Axis Motor Drive

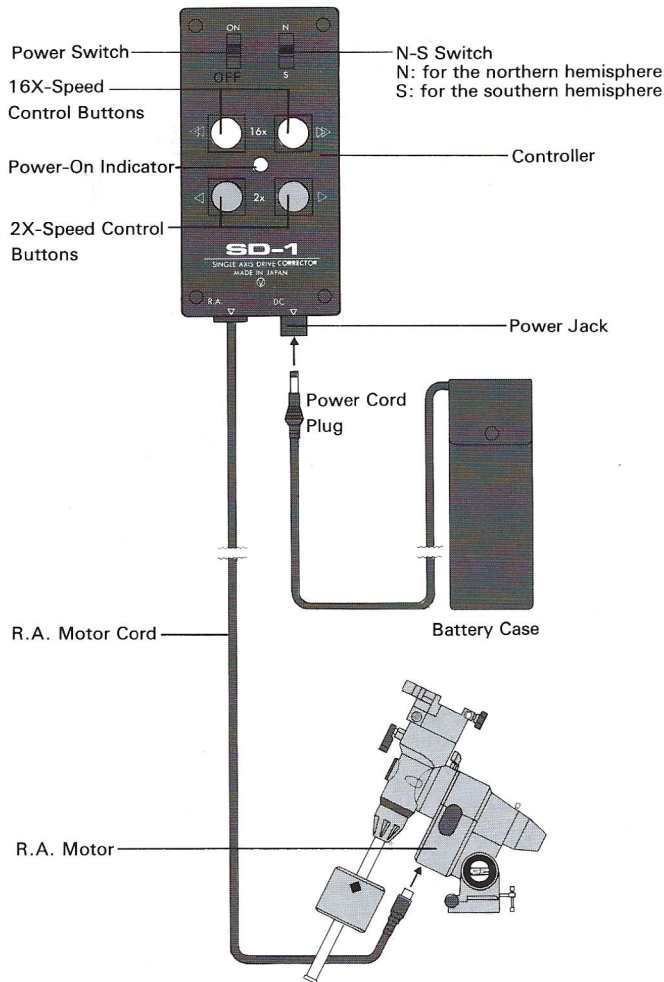

《Power Source - DC6.5V to 12V》

① Dry Cell Battery

Place 6 C-size batteries into the battery case, making sure not to put them in the wrong way.

② Car Battery

To get power from a cigarette lighter receptacle, use a car battery cord with a cord plug illustrated below.

③ Household AC Outlet

An adapter is needed to plug into an AC outlet. Use an AC adapter with an output of DC6.5V to 12V and with a cord plug illustrated below.

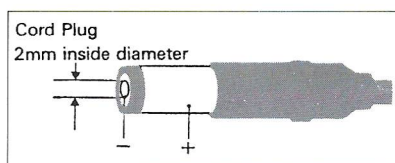

Dual-Axis Motor Drive

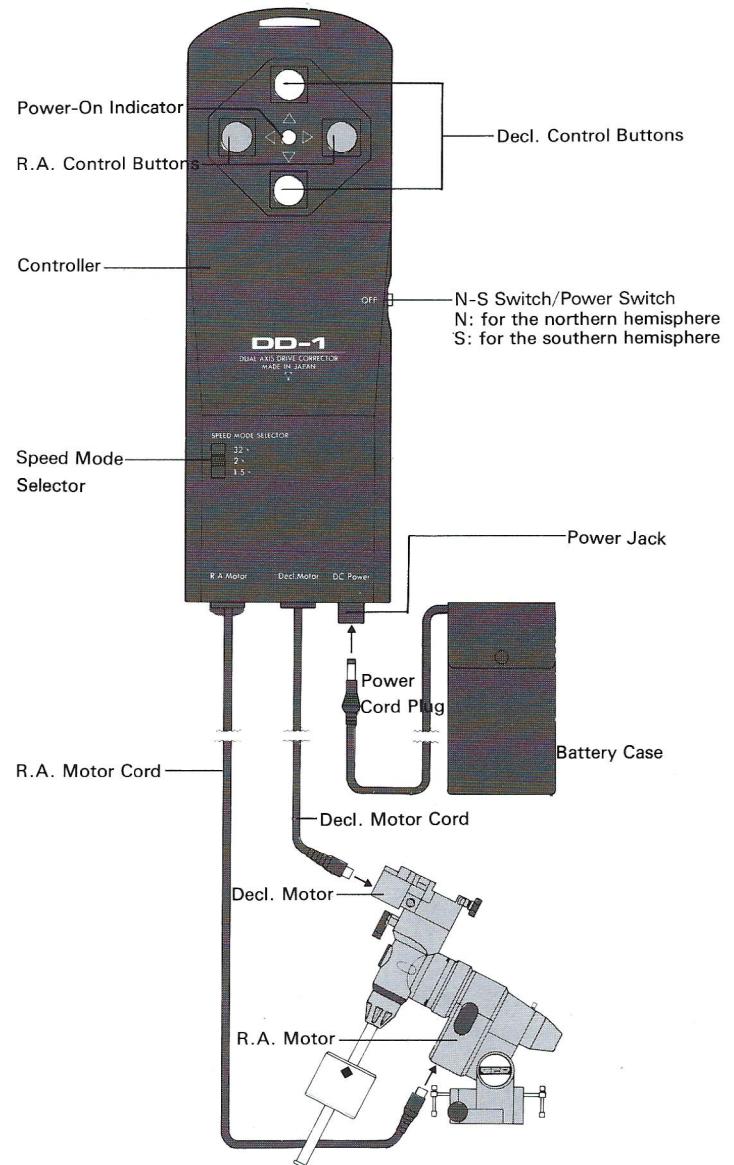

《Power Source - DC9V to 12V》

① Dry Cell Battery

Place 8 D-size batteries into the battery case, making sure not to put them in the wrong way.

② Car Battery

To get power from a cigarette lighter receptacle, use a car battery cord with a cord plug illustrated below.

③ Household AC Outlet

An adapter is needed to plug into an AC outlet. Use an AC adapter with an output of DC9V to 12V and with a cord plug illustrated below.

Motor

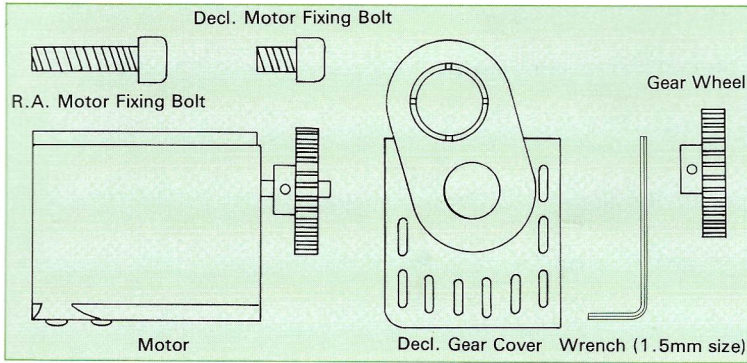

Manual Operation Clutch

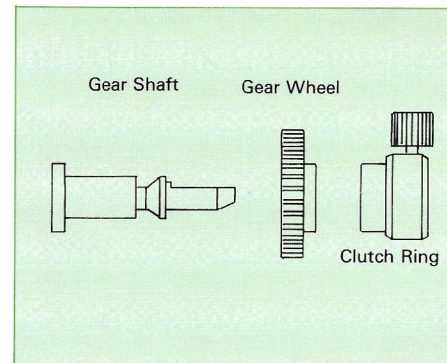
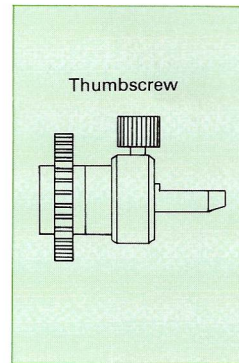

Installing the Decl. Motor

- Put the gear wheel onto the Decl. slow-motion control shaft and tighten the setscrew against the flat section of the shaft with the wrench supplied.

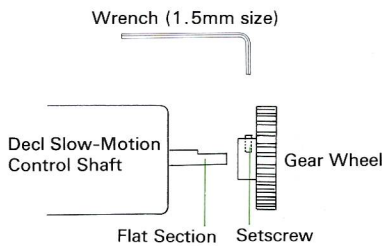
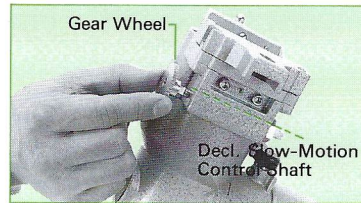

- Install the motor on the mount with the Decl. motor fixing bolt while setting the gear wheels to engage each other properly. The wrench (5mm size) to tighten the bolt is supplied for your telescope.

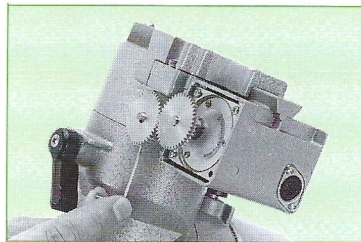
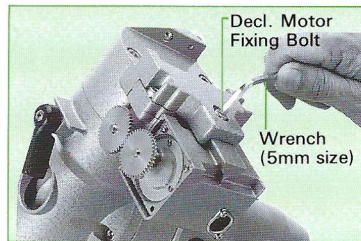

- Put the snap-on Decl. gear cover over the gears.



- Connect the Decl. motor cord to the motor.

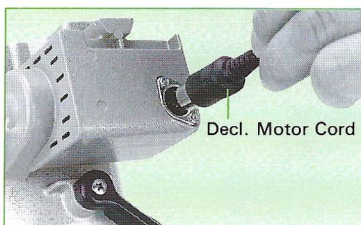

Installing the Decl. Motor and Manual Operation Clutch

- Put the gear shaft onto the Decl. slow-motion control shaft and tighten the setscrew against the flat section of the shaft with the wrench supplied.



- Attach the gear wheel to the gear shaft with the flat side facing to the outside.



- Install the Decl. motor as described.

- Cut out the outlet for the gear shaft from the Decl. gear cover and put it over the gears.



- Attach the clutch ring to the gear shaft and fasten it.



- Attach the slow-motion control knob to the gear shaft. When using the slow-motion control knob, loosen the thumbscrew on the clutch ring.



Installing the R.A. Motor

① Take off the rubber cap covering the R.A. slow-motion control shaft.

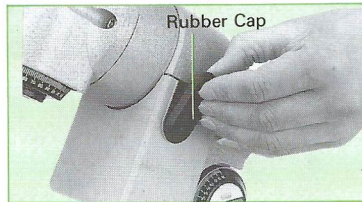

② Remove the R.A. motor cover by pulling it down after loosening its setscrew.



③ Put the gear wheel onto the R.A. slow-motion control shaft and tighten the setscrew against the flat section of the shaft with the wrench supplied.

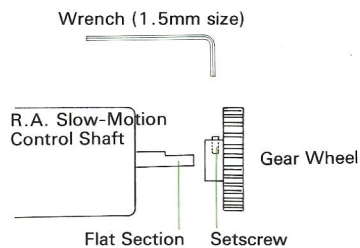
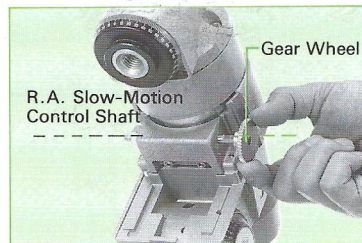

④ Install the motor on the mount with the R.A. motor fixing bolt while setting the gear wheels to engage each other properly.

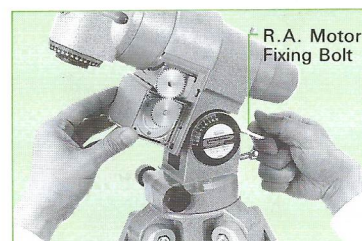

⑤ Put the R.A. motor cover onto the motor and tighten its setscrew.

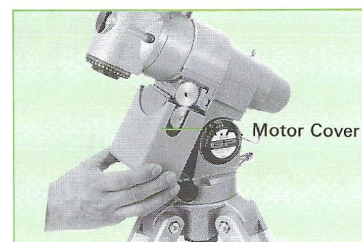

⑥ Put the rubber cap over the R.A. slow-motion control shaft.



⑦ Connect the R.A. motor cord to the motor.

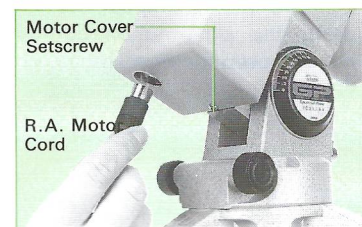

Installing the R.A. Motor and Manual Operation Clutch

① Put the gear shaft onto the R.A. slow-motion control shaft and tighten the setscrew against the flat section of the shaft with the wrench supplied.

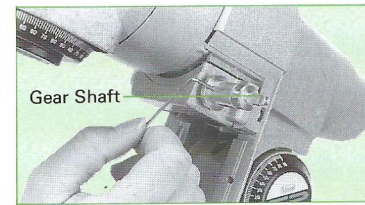

② Attach the gear wheel to the gear shaft with the flat side facing to the inside.

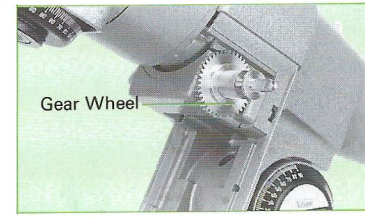

③ Install the motor on the mount with the R.A. motor fixing bolt.

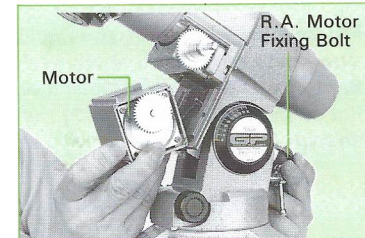

④ Adjust the gear wheels to engage each other properly.

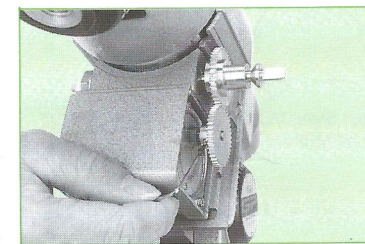

⑤ Attach the clutch ring to the gear shaft and fasten it.

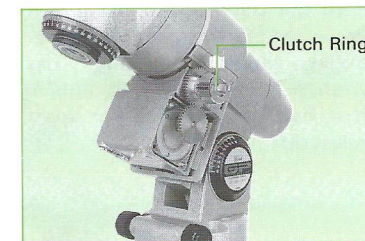

⑥ Put the R.A. motor cover onto the motor and tighten its setscrew.

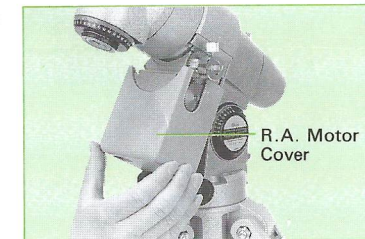

⑦ Attach the slow-motion control knob to the gear shaft. When using the slow-motion control knob, loosen the thumbscrew on the clutch ring.

